



Project \_\_\_\_\_

Item No. \_\_\_\_\_

Quantity \_\_\_\_\_



THE MATCHBOX® M360-12

**MORE AIR= BETTER QUALITY, FASTER**  
Patented air flow technology means 3x more air than traditional impingement.

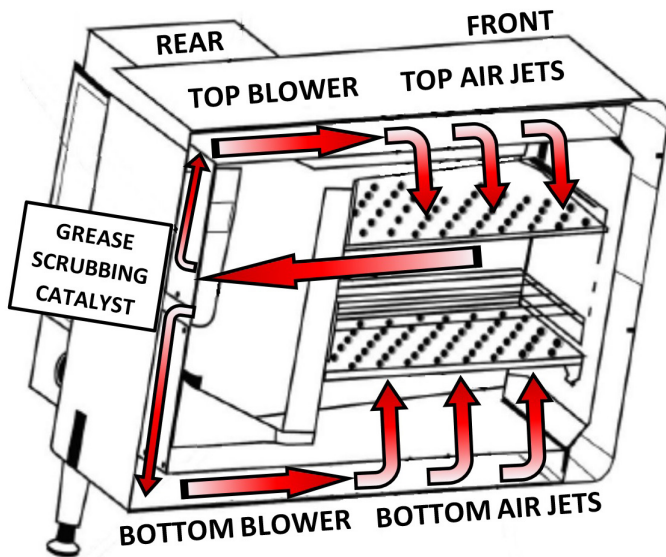

**VENTLESS OPERATION DETAILS†**

- UL (KNLZ) listed for ventless operation
- EPA 202 test: Qty (328) 12" pepperoni pizzas, 525°F, 8 hrs
  - Results: 2.01 mg/m<sup>3</sup>
  - Ventless Requirement: < 5.00 mg/m<sup>3</sup>
- Internal catalytic filtration to limit smoke, grease, and odor emissions

See [oventionovens.com/patents](http://oventionovens.com/patents) for a complete list of applicable U.S. and international patents

# The Matchbox® M360-12

## EXTERIOR CONSTRUCTION

- 430 Stainless Steel exterior
- Cool-to-touch exterior, surfaces below 55°C
- 4-inch adjustable legs
- Front-facing color 5-inch touchscreen display

## INTERIOR CONSTRUCTION

- Fully insulated 304 stainless steel cook chamber
- Patented top and bottom stainless steel triple-layer impingement jet plates
- Easy to clean design with dishwasher safe jet plates

## STANDARD FEATURES

- Integral recirculating catalytic converter for UL listed ventless operation
- Patented auto-load & unload capability with 360-degree rotating deck fits a 12-inch pizza or three 7-inch pizzas
- Patented sealed baking chamber for menu flexibility allows for 2 to 8 times the airflow rate of a typical conveyor oven, reduced cook times, energy use and HVAC loading for 40-50% lower operating costs
- FlexTemp dynamic temperature management allows ±25°F between cook cycles
- Intuitive front-facing touch control can store 600+ recipes
- Industry leading online menu & recipe software allows for easy menu creation and management via USB drive
- Self-diagnostics for monitoring oven components and performance
- Smart Voltage Sensor Technology\* manages variances in 208 & 240V operations
- Automatic Power Save mode when not cooking for maximum energy conservation
- High visibility countdown timer
- Independently controlled top and bottom Precision Impingement® air with variable-speed recirculation
- External easy-access air filtration, dishwasher safe
- 6-ft cord and plug
- 1 year Parts and Labor Warranty
- Productivity: [www.oventionovens.com/pizza-calculator-yield-per-hour](http://www.oventionovens.com/pizza-calculator-yield-per-hour)

## STANDARD OPTIONS & ACCESSORIES

- Dozens of accessory options available

## CERTIFICATIONS



This product conforms to the ventilation recommendations set forth by NFPA96 using EPA202 test method.

\* Smart Voltage Sensor Technology does not compensate for lack of or over voltage situations. It is the responsibility of the owner to supply voltage to the unit according to the product specifications.

† Ventless certification is for all food items except for foods classified as "fatty raw proteins." Such foods include bone-in, skin-on chicken, raw hamburger meat, raw bacon, raw sausage, steaks, etc. If cooking these types of foods, consult local HVAC codes and authorities to ensure compliance with ventilation requirements. Ultimate ventless allowance is dependent upon AHJ approval, as some jurisdictions may not recognize the UL certification or application. If you have questions regarding ventless certifications or local codes, please email [connect@oventionovens.com](mailto:connect@oventionovens.com).





# The Matchbox® M360-12

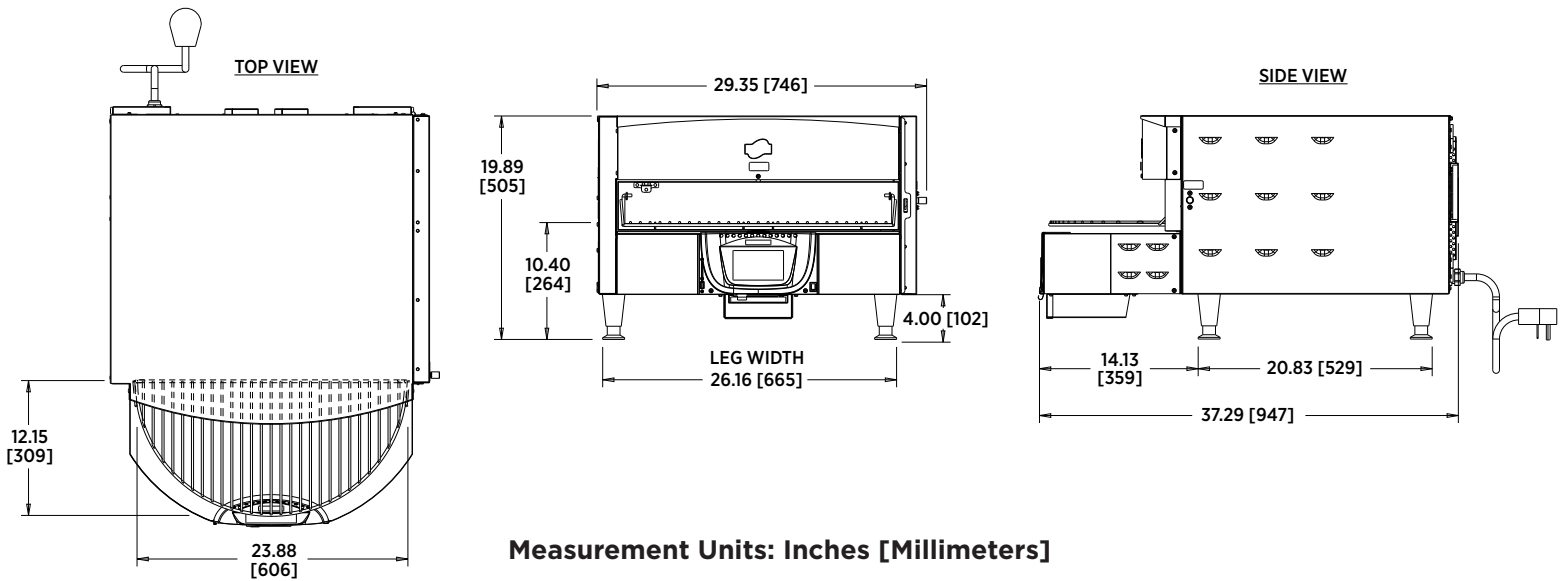

DIMENSIONS		
HEIGHT	19.89"	505 mm
WIDTH	29.35"	746 mm
DEPTH	37.29"	947 mm
WEIGHT	211 lb.	84 kg
CAVITY DIMENSIONS		
HEIGHT	3.5"	89 mm
WIDTH	23.9"	607 mm
DEPTH	12.3"	311 mm
MINIMUM CLEARANCE		
LEFT/RIGHT/BACK	0/2/0"	0/51/0 mm
SHIPPING INFORMATION		
CUBE (LxWxH)	32 x 40 x 49"	812 x 1016 x 1244mm
SHIPPING WT.	275 lb.	125 kg
FREIGHT CLASS	175	
POINT OF ORIGIN	Sturgeon Bay, WI, USA	

ELECTRICAL SPECIFICATIONS			
US/CANADA	208-240 VAC, 60 Hz, 1-ph, 25/28 Amps, cULus, NEMA 6-30P and cord - standard	Max Input: 6.9kW Heater Input: 6.4kW	 NEMA 6-30
INTERNATIONAL 1-ph	230 VAC, 50 Hz, 1-ph, 27.5 Amps CE, IEC 60309 2P+PE, 36A	Max Input: 6.9kW Heater Input: 6.4kW	 IEC 60309 2P+PE
INTERNATIONAL 3-ph	230-400 VAC WYE, 50 Hz, 3-ph, 13.5 Amps, CE, IEC 60309 3P+N+PE, 16A	Max Input: 6.9kW Heater Input: 6.4kW	 IEC 60309 3P+N+PE

## SHORT FORM SPECIFICATIONS

Provide Ovention Matchbox® M360-12 Precision Impingement® Conveyor Oven, Ventless, Rapid Cook, countertop, 360-degree rotating cooking platform with auto load/unload, 24" wide sealed cook chamber, triple-nozzle impingement plates, touch screen display, built-in self-diagnostics, USB menu upload, smart voltage sensor technology, automatic power save mode, FlexTemp dynamic temperature management, cool to touch 430 ss exterior, 304 ss interior, 4" adjustable legs, Made in USA, cULus, CE, UL EPH Classified, ANSI/NSF 4.

Due to periodic changes in designs, methods, procedures, policies and regulations, the specifications contained in this sheet are subject to change without notice. While Ovention® exercises good faith efforts to provide information that is accurate, we are not responsible for errors or omissions in information provided or conclusions reached as a result of using the specifications. By using the information provided, the user assumes all risks in connection with such use.

