



Project:  
Item:  
Quantity:

**COMBIVAC BOXER 52II**  
**CHAMBER VACUUM SEALER**



- FEATURES**
- Seal bar length: 2x16"
  - Seal bars with two wires, for double security
  - Seal bars easily removable for cleaning and maintenance purposes
  - Pump capacity: 889 cf/h (25 m<sup>3</sup>/h) Busch vacuum pump
  - Pump maintenance and cleaning program
  - Machine cycle: 20-40 sec
  - **Standard CombiVac control system** with 20 program memory and Sensor control: max. 99.8%, for an optimum and consistent vacuum and cycle time
  - Soft Air to protect the product and vacuum pouch
  - Transparent lid, which opens automatically after every cycle
  - Deep drawn vacuum chamber
  - Comes with insert plates for a faster cycle and product adjustment
  - Stainless steel exterior
  - 6ft cord with Nema 5-20P plug
  - Standard with service kit

**DESCRIPTION**  
The robust, stainless steel Boxer 52II vacuum sealer is standard equipped with a Busch vacuum pump. This CombiVac table-top model is ETL listed and complies with UL, CSA and CE standards.

- OPTIONS AND ACCESSORIES**
- Liquid control
  - Inclined insert plate
  - Cut-off/Wide seal (\$0)
  - Label printer
  - Food container adaptor



**WARRANTY**  
Henkelman Inc offers a warranty of 1 year on labor and 3 years on parts. For full warranty details, please refer to [www.henkelman.com](http://www.henkelman.com).

**DATE** **APPROVAL**

**ORIGINAL HENKELMAN VACUUM SYSTEMS**  
**FIT FOR FOOD SERVICE**  
<https://www.henkelman.com/us>

**HENKELMAN INC.**  
493 W Fullerton Ave  
Elmhurst IL, 60126

**Sales and technical support**  
P +1 331 979 2013  
F +1 630 359 3875  
E [info@henkelmanusa.com](mailto:info@henkelmanusa.com)

**Service and warranty**  
P +1 844 208 5685

**COMBIVAC VACUUM SEALER BOXER 52II - SPEC SHEET**

# COMBIVAC VACUUM SEALER BOXER 52II – SPECS

COMBIVAC VACUUM SEALER BOXER 52II – SPEC SHEET

## DIMENSIONS

In inches

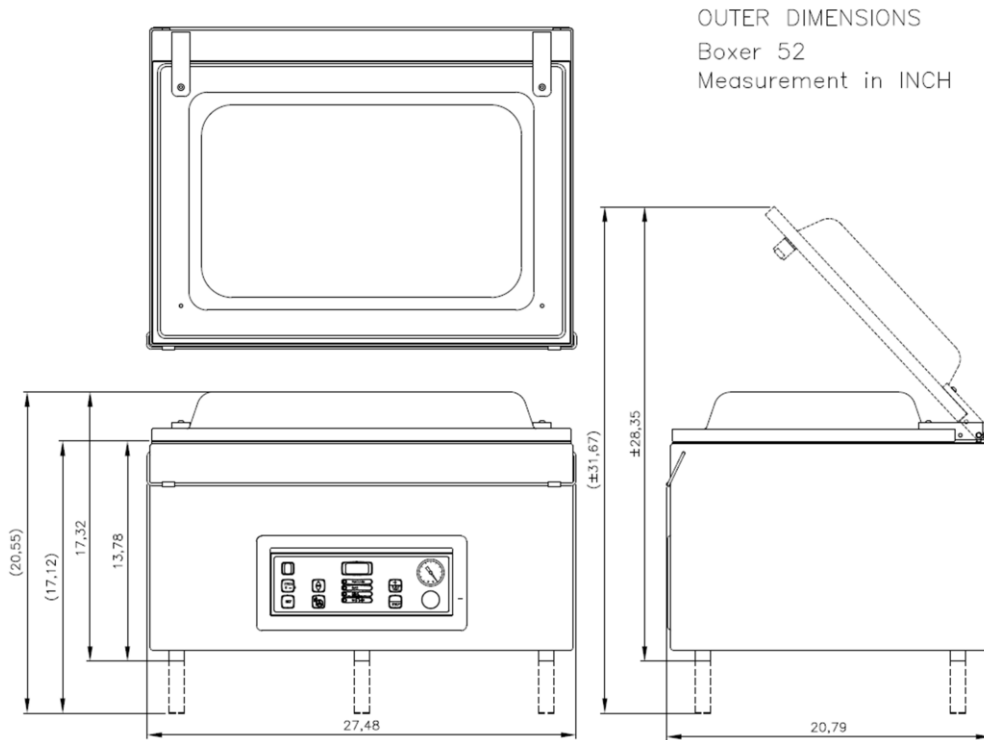

Model	Dimensions (inches)		Volts	Amps	Hz	Pump capacity	HP	Plug	Weight (lbs)
	Chamber (usable space) LxWxH	Machine LxWxH							
Boxer 52II CombiVac	16"x20.5"x7"	20.8"x27.5"x17.3"	110-120V	16	60Hz	889 cf/h (25 m <sup>3</sup> /h)	1.34	NEMA 5-20P	179

NEMA 5-20P



20 A/125 V



FIT FOR FOOD SERVICE

<https://www.henkelman.com/us>

HENKELMAN INC.  
493 W Fullerton Ave  
Elmhurst IL, 60126

Sales and technical support

P +1 331 979 2013

F +1 630 359 3875

E [info@henkelmanusa.com](mailto:info@henkelmanusa.com)

Service and warranty

P +1 844 208 5685