



Project _____

AIA # _____ SIS # _____

Item # _____ Quantity _____ C.S.I. Section 114000

R-Series

W-Width Pass-Thru Refrigerator Model
Glass Door, 26" Deep, Self-Contained



STANDARD PRODUCT FEATURES

- Traulsen's Smart Control with LED Display
- StayClear™ Condenser Coil
- Stainless Steel Exterior & Interior
- Balanced, Self-Contained Refrigeration System Using R-450A
- Rear Biased Return Air Duct
- Full or Half-Height Glass Doors with Locks
- Anti-Condensate Door Perimeter Heater
- Self-Closing Doors with Stay Open Feature at 120 Degrees
- Stainless Steel Vertical Door Handles
- Standard Door Hinging F & R: 226WP = Left/Right (other hings available)
- LED Lights with Exterior Switch
- Stainless Steel Breaker Caps
- Three Adjustable, Coated Wire Shelves Per Section, Supported on Shelf Pins (factory installed)
- Automatic Non-Electric Condensate Evaporator
- Magnetic Snap-In EZ-Clean Door Gasket(s)
- Thermostatic Expansion Valve Metering Device
- Stainless Steel One-Piece Louver Assembly
- 9' Cord & Plug Attached
- Set of (4) 6" High Adjustable Stainless Steel Legs



Intertek



This unit is listed to the applicable UL, CSA and NSF Standards by an approved NRTL. Consult the factory or unit's data plate for approval information.

ACCESSORIES & OPTIONS

- Additional Coated Wire or Optional Stainless Steel Shelves
- Locking Hasps (padlocks supplied by others)
- Export 220/50/1 Voltage
- 208-230/115/60/1 or 208/60/1 Voltage in Lieu of Standard 115/60/1
- Kool Klad Exterior Laminate Decor
- Set of (4) 4⁵/₈" or 6" High Casters in Lieu of Legs
- Other Support Options: 4¹/₂" High Base or 6" High Kickplate (for use with standard legs)

AVAILABLE CONFIGURATIONS

R-Series Models

RHT226WPUT-FHG
RHT226WPUT-HHG

Door(s)

Full Height Glass
Half Height Glass

***Remote application available,
see form TR35837 for details.**

- GUARANTEED FOR LIFE CAM-LIFT HINGES

Approved by _____ Date _____ Approved by _____ Date _____



R-Series

W-Width Pass-Thru Refrigerator Model
Glass Door, 26" Deep, Self-Contained

MODEL

RHT226WPUT-HHG
RHT226WPUT-FHG

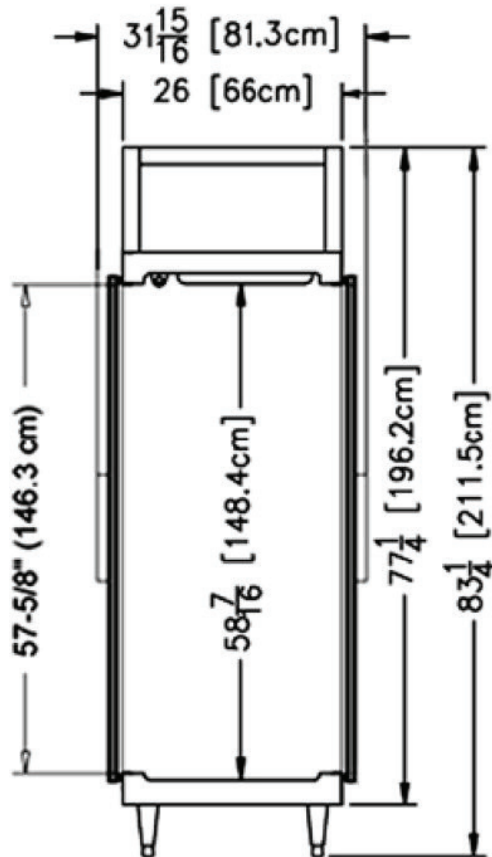
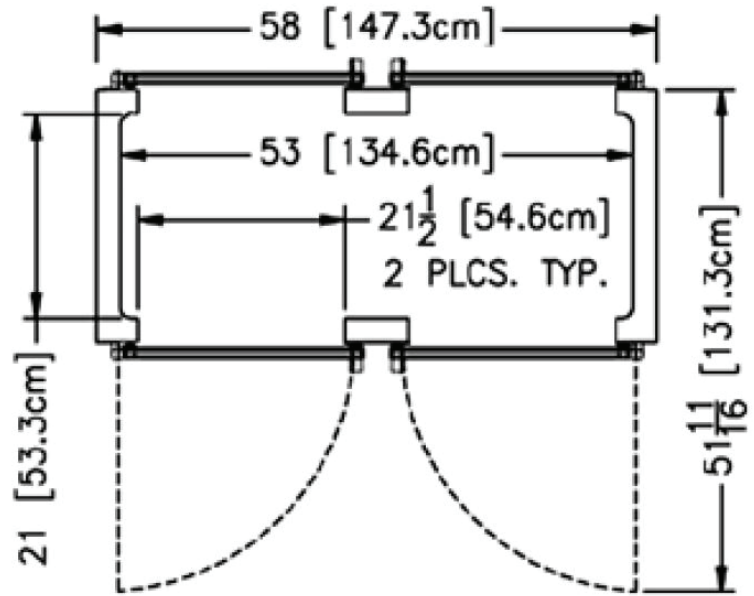
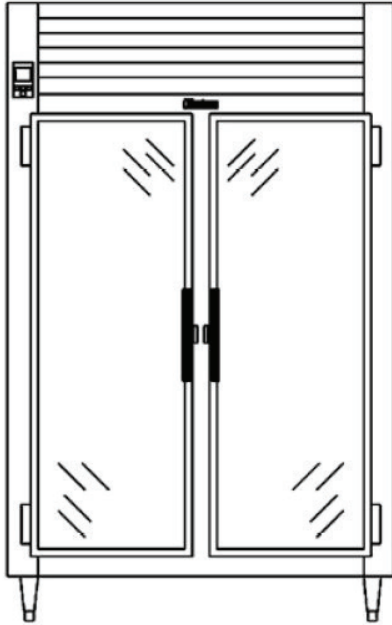

CAD and/or Revit Files Available

<https://traulsen.klccad.com/>



R-Series

W-Width Pass-Thru Refrigerator Model Glass Door, 26" Deep, Self-Contained

MODEL

RHT226WPUT-HHG
RHT226WPUT-FHG

EQUIPMENT SPECIFICATIONS

MODELS	RHT226WPUT
DIMENSIONAL DATA	
Net capacity cu. ft.	44.3 [1254.4 cu l]
Length - overall in.	58" [147.3 cm]
Depth - overall in.	31 15/16" [81.2 cm]
Depth - over body in.	26" [66 cm]
Depth - door open 90° in.	76 7/16" [194.48 cm]
Clear door width in.	21 1/2" [54.6 cm]
Clear half-door height in.	27 1/2" [69.9 cm]
Clear full-door height in.	57 5/8" [146.3 cm]
Height - overall on 6" legs ²	83 1/4" [211.5 cm]
No. Standard Shelves	6
Shelf area sq. ft. ³	20.18 [1.88 sq. m]
ELECTRICAL DATA	
Voltage Plug	115/60/1 NEMA 5-20P
Full Load Amperes MDEC ⁴	11.8 5.03 kWh/Day
REFRIGERATION DATA	
Refrigerant	R-450A
Refrigerant Charge Amount oz.	27 [765.4 g]
BTU/HR H.P. ¹	4200 1/2 HP
SHIPPING DATA	
Length - Crated in.	62" [157.5 cm]
Width - Crated in.	42" [106.7 cm]
Height - Crated in.	85" [215.9 cm]
Volume - Crated cu. ft.	128.09 [3627.1 cu l]
Weight - Crated lbs.	788 [357.4 kg]

NOTES: Figures in parentheses reflect metric equivalents.

1. Based on a 90°F ambient and 20°F evaporator.
2. 12" Top clearance preferred for optimum performance & service access.
3. Area of standard shelf complement only, does not include storage area of additional shelves or available on cabinet bottom.
4. MDEC = Maximum Daily Energy Consumption

CONSTRUCTION, HARDWARE, INSULATION

The cabinet interior, exterior front, one piece sides & louver assembly are made from heavy-gauge stainless steel. The exterior top & bottom are made from heavy-gauge galvanized steel. Included is a set of four adjustable 6" stainless steel legs.

Doors have removable plug cylinder locks & guaranteed for life gravity action, self-closing glide hinges that stay open at 120 degrees. An external switch is included to activate interior LED lighting. The gasket design simplifies cleaning & enhances longevity. Anti-condensate heater located behind each door. The unit has seamless, polished metal corners & vertical stainless steel handles. The cabinet is insulated with high density, non-CFC, foamed in place polyurethane.

SELF-CONTAINED REFRIGERATION SYSTEM

The unit uses a top-mounted, balanced system located behind the one piece louver assembly. The R450A refrigerant is environmentally friendly & non-flammable. It features a finless StayClear™ condenser, thermostatic expansion valve, air-cooled hermetic compressor, plenum effect blower coil, large, high humidity evaporator coil outside the food zone & a top-mounted non-electric condensate evaporator.

The biased return air duct protects against warm kitchen air, promoting consistent temperatures & efficient operation. Operating temperatures are 34-38°F. A 9' cord and plug are provided.

CONTROL

Traulsen's Smart Control features advanced control algorithms & sophisticated diagnostic capabilities to optimize performance. Utilizing Smart Sensors, it adapts the operation of the refrigeration system to a variety of environments & usage patterns. The Smart Control also offers a complete set of visual alarms designed to alert the user to critical events such as power outages or a prolonged door opening. In the event of an alarm, a dedicated Alarm LED will illuminate, informing the user of the critical event and duration.

INTERIOR

The interior includes three factory installed pin-mounted, full-width coated wire shelves per section with no large gaps. Each shelf can support up to 225 lbs. Factory installed optional trayslides may be purchased in combination with, or in lieu of these.

WARRANTY

Both a six year parts & labor warranty and a seven year compressor warranty (self-contained models only) are provided standard.

When ordering please specify: Voltage, Hinging, and Options

Equipped with one NEMA 5-20P Plug



CONTINUED PRODUCT DEVELOPMENT MAY NECESSITATE SPECIFICATION CHANGES WITHOUT NOTICE.