

ELECTRIC TILT BRAISING PAN 29 GALLON 95,500 BTU, 5.8PSI WITH LIFT



UDBRG029ACV1

General Functional Features

- Heating by means of high efficiency stainless steel tube burners
- Automatic ignition and flame control system without pilot burner
- Heating controlled by electronic board
- Temperature control by system with two probes (product/bottom)
- Pressure cooking with automatic system for eliminating air from the cooking container (for cooking with saturated steam) and automatic steam condensation after cooking to allow fast and safe lid opening without steam dispersion in the room
- Core probe, fixed at the lid, standard
- Automatic baskets lifting system by electric engines controlled by electronic card
- Electronic control by means of multifunctional keyboard with Touch Screen 7" and easy and clear messages
- USB connection to download HACCP data, update the software and load cooking programs
- Ability to interrogate the machine using communication protocol MODBUS over RS485 serial interface

Panel Board Functions

- ON/OFF switch
- Resistive 7" touch screen
- Keys for moving basin
- Selection of 7 different cooking modes, with working temperature setting
- Cooking type and time setting
- Set the cooking time using the basket lifters, with possibility to select automatic lowering when the temperature is reached
- Cooking in "Manual" mode
- Cooking in "Program" mode
- Creating and editing multiphase cooking programs, setting for each phase: type of cooking; cooking parameters (temperature and time), and possibility to insert text messages
- Tank water load setting (hot up to 140° F/cold) with automatic liter measurements
- Control for tilting and return of cooking tank from Touch Screen or keyboard
- Delayed cooking setting with date, time, and programming cycle
- Language settings Touch Screen
- Input of different units of measurement (° C/° F; Liters/gallons; etc)

Display/Signal

- Display type of cooking, temperature probes used and set temperature
- Heating operating visual alarm
- Time to end of cycle display
- Audible/visible warning of automatic basket movements
- Tank pressure display
- Reporting lid locking and condensing time during cooking under pressure
- Display tank out of position for cooking
- Signaling tap position, managing water in the tank
- Signal of lid and cock position during vat tilting
- Signaling and blocking heat in case there is no gas
- Gas control unit "RESET" message
- Thermostat intervention safety signaling
- Self-diagnostics

Safety System

- Emergency button
- Blocking of heating for excess of temperature with manual resettable safety thermostat
- Mechanical lid opening lock with tank under pressure
- Lid safety valve
- Heating interruption during vat tilting

OPTIONS & ACCESSORIES AT ADDITIONAL COST

- | | | |
|---|---|--|
| <input type="checkbox"/> DAPF0010 - SET FEET | <input type="checkbox"/> D150 - KIT WHEELS | <input type="checkbox"/> DAP01000 - SPATULA FOR OMELETTE |
| <input type="checkbox"/> DADE0010 - CLEANING SHOWER | <input type="checkbox"/> DAF0110 - STRAINER | <input type="checkbox"/> DABF0000 - CONTANIER WITH HOLES |

STANDARD CONSTRUCTION SPECIFICATIONS

Cooking vessel in stainless steel AISI 304 (bottom thickness 15 mm and wall thickness 2,5 mm) with rounded corner angles and anti-overflowing lip. Vessel with electric tilting on front part

Lid in stainless steel AISI 304 (thickness 20/10), with double cover, with ergonomic handle, reinforced with locking system at 4 points on sliding shafts and lever type control bolts with blocking of opening under pressure. Alimentary silicone gummy gasket with only one jointing point. Balanced by means of gas springs

Self-supporting frame in stainless steel AISI 304 (thickness 30-40/10)

Outer cover in stainless steel AISI 304, fine satin finish (thickness 12-15/10)

Adjustable feet in stainless steel AISI 304 to ensure levelling, with removable cover for cleaning operations

Fast accessibility to the main functional parts (electronic card, fuses, thermostats...) only removing the frontal panels

Protection level IPX4



Approval Notes: _____

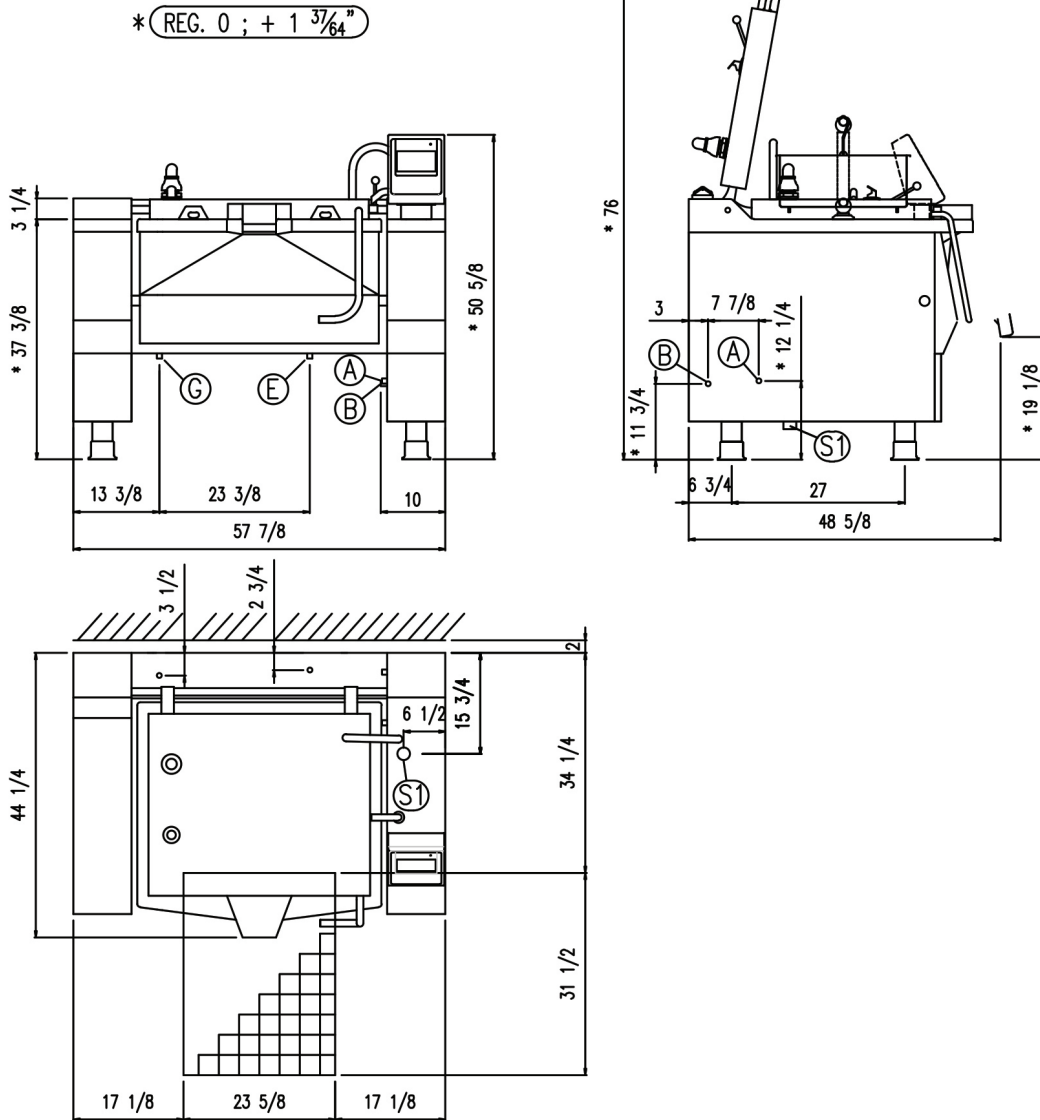

TECHNICAL SPECIFICATIONS

| DIMENSIONS | | | | | | Weight | Capacity | Cooking Vessel Surface |
|------------|---------|---------|--------------|--------------|---------------|---------|----------|------------------------|
| Width | Depth | Height | Vessel Width | Vessel Depth | Vessel Height | | | |
| 57 7/8" | 44 1/4" | 50 5/8" | 31 3/4" | 25 5/8" | 16 1/2" | 1014 lb | 29 gal | 806 in ² |

| UTILITIES | | | | | | | | |
|---------------------|----------------------|----------------|--------------------|-----------------|-------------------------|--|----------------|---------|
| HOT WATER INLET (A) | COLD WATER INLET (B) | WATER PRESSURE | GAS CONNECTION (G) | GAS POWER BTU/H | STD VOLTAGE (E) | | ELECTRIC POWER | CURRENT |
| 3/4" | 3/4" | 25-50 PSI | 3/4" | 95,500 | 3 PHASE 208V~ 60Hz | | 0.50 kW | 2.4 A |
| | | | | | 3 PHASE 220-240 V~ 60Hz | | 0.50 kW | 2.1 A |

**INTENDED FOR COMMERCIAL USE ONLY.
NOT FOR HOUSEHOLD USE.**

