



WLR60B-D2

Worktop 60" Refrigerator with One Door and Two Drawers



WLR60B-D2
09/09/24
Item # 13700

W x D x H

60" x 33.25" x 40.25"*
*with 6" casters



Item #: _____

Project: _____

Qty: _____

AIA#: _____

Features

- ▶ Engineered to maintain NSF-7 temperatures in 100°F ambient.
- ▶ Stainless steel exterior front, sides, and top with stainless steel interior sides, back, and floor
- ▶ Front breathing air flow design
 - Environmentally friendly R290 hydrocarbon refrigerant
 - Cabinet and drawers are insulated with 2" CFC free, foamed in place polyurethane
 - Drawer module frames, acetal rollers, and drawer stops are formed of heavy duty stainless steel all welded construction and securely fastened in the cabinet
 - Drawer slides are constructed of 14 gauge stainless steel with acetal rollers
 - Drawer slides have a dynamic load capacity of 250 lbs.
 - Drawer frames are formed of 14 gauge stainless steel and securely fastened in the cabinet
 - Drawers will accommodate (2) 12 x 10" half size pans and (2) 12 x 6.5" 1/3 size pans, 6" deep pans (pans by others)
 - Extruded aluminum flush mount door/drawer handle
 - Field reversible doors with magnetic snap in gaskets
 - Shelves hold a full- size sheet pan & 120 lbs. capacity
 - Two epoxy coated shelves per section is standard
 - Anodized aluminum shelf supports adjustable in 1/2" increments
 - Magnetic door gasket is easily removable for cleaning
 - Digital temperature display
 - Removable air filter for easy cleaning
 - Hot gas condensate removal
 - Mullion heaters for reduced condensation
 - E-coated evaporator coil
 - Standard with 6" casters (two with brakes)
- 10 ft. cord and plug

Door or drawer can be located in any section of the cabinet. Location must be indicated at time of ordering.

If GFCI is required, a GFCI breaker MUST be used in lieu of GFCI receptacle

Hoshizaki reserves the right to change specifications without notice.



Dimensions / Capacity

Interior Storage Capacity (CF) (AHAM)	17.22 ft ³
Overall Width x Depth (including 1" bumper)	60" x 33.25"
Height (including 6" casters)	40.25"
Door/Drawer Opening Width x Height	19.5" x 23" (door) / 19.5" x 9" (drawer)
Depth with Door Fully Open (including 1" bumper)	54.75"
Depth with Drawer Fully Open (including 1" bumper)	57.5"
Adjustable shelves / Shelf Dimensions (W x D)	2 / 21.5" x 25.5"
Crated Weight	385 lbs.
Crated Length x Width x Height	63.75" x 35.75" x 40"

Two-Section WLR60B-D2

Electrical / Refrigeration

Voltage	115/60/1
HACR Breaker	15.0 Amps
Electrical Connection (NEMA)	5-15P ⚡
Voltage Range	104-126
Ambient Temp. Range	45° to 100°F
Control Setpoint Range	28° to 45°F
Amperage	3
Energy Consumption (kWh/day) @NSF	1.26
Heat Rejection (BTU/Hr.) @NSF	305
Approx. Nominal Compres. BTU/HR (HP)	1354 (1/5HP)
Refrigerant / Charge Amount (oz)	R290 (2.2 oz)

Two-Section WLR60B-D2

Options

- 2" Casters (HS-5037, set of 4)
- 4" Casters (HS-5035, set of 4)
- Foot pedal kit (HS-5555, Lft hinge)
- Foot pedal kit (HS-5556, Rt hinge)
- Door/Drawer Locks (factory request)
- Reversible door (field reversible)
- Stainless steel back panel (factory request)
- Overshelves (HS-5639 single)
- Overshelves (HS-5640 double)
- Addtl. Epoxy Shelves (HS-5579, 1pk)
- Addtl. Stainless Shelves (HS-5580, 1pk)
- Drawer divider bar (HS-4007, Vertical)
- Drawer divider bar (HS-5692, Horizontal)



Valid in United States, Canada, Puerto Rico and U.S. Territories. Contact factory for warranty in other countries.



WLR60B-D2

Worktop 60" Refrigerator with One Door and Two Drawers



WLR60B-D2
09/09/24
Item # 13700

FRONT VIEW

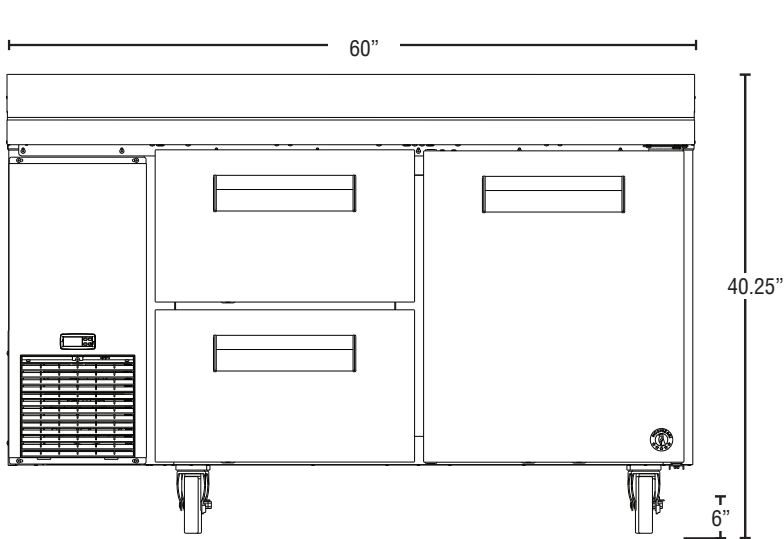

SIDE VIEW

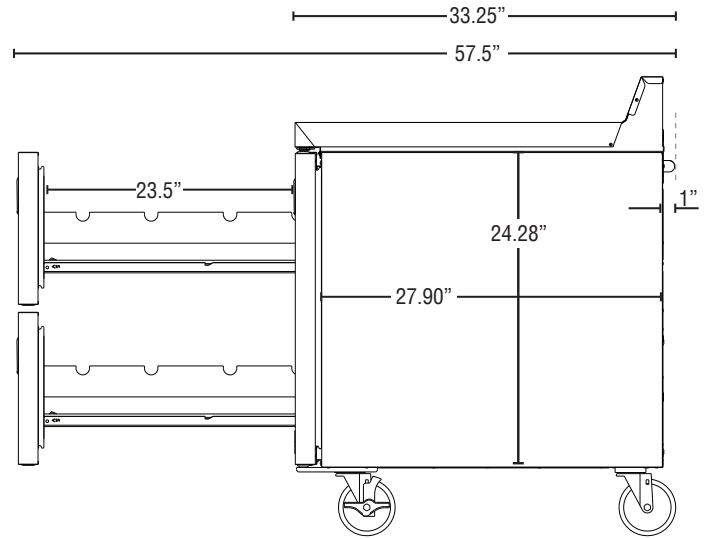

PLAN VIEW

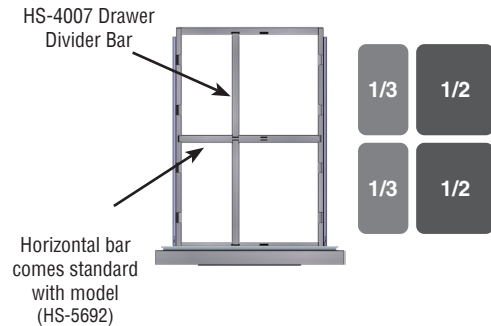
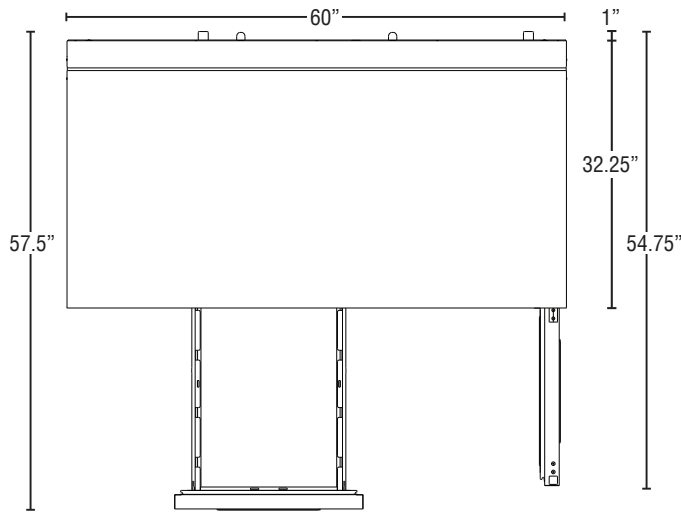

Cabinet Construction

The exterior cabinet top, front, and sides, are constructed of high quality stainless steel. The exterior back and bottom are constructed of coated steel. The cabinet interior features stainless steel back, sides, and floor with an ABS top. One heavy duty epoxy coated shelf per section is standard. Mounted on anodized aluminum pilasters the shelves are adjustable in 1/2" increments. Cabinet walls and doors are insulated with 2" of environmentally friendly, CFC free, foamed in place polyurethane. 6" polyolefin, stem casters (two with brakes) are standard.

Door Construction

Doors are constructed of high grade stainless steel exterior with an ABS interior liner and are insulated with 2" CFC free, foamed in place polyurethane. Hoshizaki's exclusive "stepped" design protects the gasket while product is removed from the cabinet. Doors are provided with a one piece, extruded aluminum, flush mount handle. Spring assisted self-closing doors are equipped with a stay open feature past 90° degrees. Snap-in magnetic door gaskets are durable and easily removed for cleaning. Field reversible door hinging is standard.

Drawer Construction

Drawer fronts are constructed of high grade stainless steel inside and out and are insulated with 2" CFC free foamed in place polyurethane. Each drawer accommodates (2) 12" X 10" X 6" and (2) 12" x 6" x 6" deep pans (pans by others). Drawer module frames are formed of 14 gauge stainless steel all welded construction and securely fastened in the cabinet. The drawer slides are constructed of 14 gauge stainless steel with delrin nylon rollers to prevent metal to metal contact between the drawer slides and help reduce wear. The drawer slides have a dynamic load capacity of 200 pounds. Drawers are provided with a one-piece extruded aluminum flush mount handle. Snap-in magnetic drawer gaskets are durable and easily removed for cleaning.

Refrigeration System

The high efficiency refrigeration system is self-contained with an E-coated evaporator for extended life. Condensate removal is accomplished with an energy efficient non-electric evaporation system. A capillary tube controls the flow of environmentally friendly R290 refrigerant through the evaporator. Refrigeration system utilizes an "off cycle" defrost to eliminate any ice on the evaporator coil. 115 volt units are equipped with a ten foot cord and plug (20.0 amps or less).