

NE-2180 SONIC STEAMER

Panasonic

PREMIUM
FOOD SERVICE
EQUIPMENT

www.panasonic.com/CMO

MEET YOUR NEW PREP COOK

NO WATER LINE OR RESERVOIR | NO HOOD REQUIRED | PORTABLE | 2100 WATT

Powered by microwave technology | Top and bottom energy feed with 4 magnetrons
Holds two full-size 4" tall steam pans with covers | 16 customized programs



the POWER of **STEAM**



EFFICIENT, FAST AND PRECISE HEAT YIELDS A SUPERIOR-QUALITY PRODUCT

Super green broccoli | Perfectly cooked seafood | Gently steamed buns

Ideal for heavy-volume steaming and microwave applications in restaurants, supermarkets, delicatessens, school food service, health care, banquets and buffets, catering services, arenas and large venues.

NE-2180 SONIC STEAMER

Panasonic

PREMIUM
FOOD SERVICE
EQUIPMENT

WHY SONIC STEAMER?

High wattage allows the steamer to deliver effective, accurate heat that leaves products perfectly cooked. No soggy, brown broccoli here!

PERFORMANCE

- 3 stage cooking
- 5 power levels (HI, MED, LOW, DEF, HOLD)
- 8 programmable memory pads
 - 16 total memory capability
- Timer: maximum times for power levels:
 - Hi+Med: 15 minutes
 - Low, Def., Hold: 60 minutes
- Programmable / dial timer to select cooking time

ADDITIONAL FEATURES

- XL oven capacity of 1.6 Cu.Ft.
- Drop down “grab and go” door
- Stainless steel cabinet & cavity
- See-through oven door
- Removable center shelf
- Digital display
- 4 heating elements (magnetrons)
- Top and bottom energy feed
- Holds two 4” tall full-size steam pans with covers

MAINTENANCE

- Self-diagnostics
- Easy to clean air filters
- Easy to change interior oven light

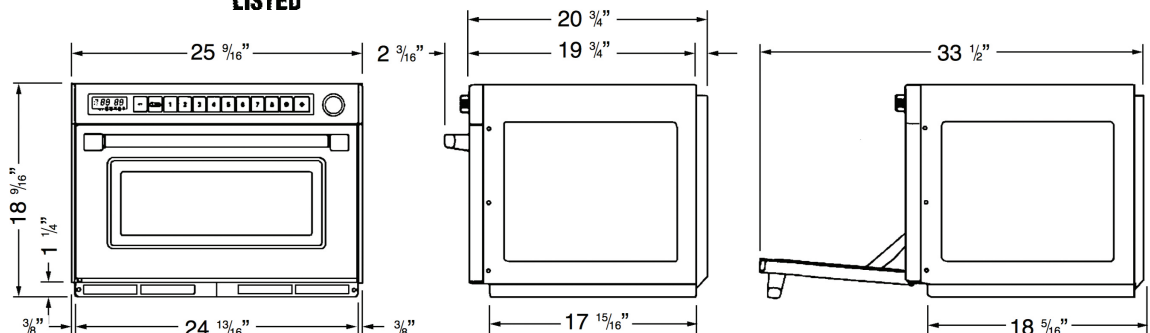

CULINARY PERFORMANCE

Category	Product	Minute/Lb	Yield/Hour
Seafood	Shrimp	1:30	40
	Lobster	2–2:30	35
	Fish	2:40	20
Vegetable	Asparagus	0:55	72
	Potato	2:30	60
	Green Beans	1:40	42
	Broccoli	2:15	45
Meat	Meatballs	2:40	40
	Hot Dogs	1:00/dozen	52 dozen

Find more recipes, applications and suggested cook times in our Sonic Steamer Cookbook, free online!

SPECIFICATIONS

Model	NE-2180
Power Source	208/230-240 V, 60 Hz, single phase
Receptacle Required	30 AMP, NEMA 6-30R (see illustration)
Output*	2100 Watts
Outer Dimensions (WxDxH)	25 9/16" x 20 3/4" x 18 9/16"
Oven Dimensions (WxDxH)	21 1/16" x 13" x 9 7/8"
Net Weight	137 lbs.
Shipping Weight	148 lbs.
Shipping Carton	29 7/8" w x 26 1/8" d x 22 1/4" h
Frequency	2,450MHz
Warranty	1 year Parts/Labor, 3 year on magnetron

The NE-2180 commercial microwave meets or exceeds all safety performance and sanitation standards set for commercial food service microwave ovens by UL, HHS, FCC and NSF.