



Project:
Item:
Quantity:

POLAR 2-40 COMBIVAC
DOUBLE CHAMBER
VACUUM PACKING MACHINE



FEATURES

- Seal bar length: 2 x 24.4"
- **Standard Advanced Control (CombiVac)** with Sensor control: max. 99.8% end vacuum
- Standard double seal (seal bars with two wires, for double security)
- Available for free: Cut-off or Wide seal
- Seal bar system mounted in lid and easily removable for cleaning and maintenance purposes
- Pump capacity: 2,780 cf/h (75 m3/h) Busch vacuum pump
- Pump maintenance and cleaning program
- Machine cycle: 15-40 sec
- Red meat function
- Soft Air (gentle air return)
- Stainless steel lid
- Flat working plate
- Comes with insert plates for a faster cycle and product adjustment
- Stainless steel exterior
- 12ft cord with NEMA 14-50P plug

DESCRIPTION

The robust, stainless steel Polar 2-40 double chamber vacuum packaging machine is standard equipped with a Busch vacuum pump. This machine is ETL listed and complies with UL, CSA and CE standards.

OPTIONS AND ACCESSORIES

- Digital control with 10 program memory and Sensor control
- External pump
- 1-2 Cut-off seal/Bi-active seal
- Gas flush
- Inclined insert plate
- Liquid control
- Zebra ZD410 thermal label printer (only in combination with CombiVac control)
- Service kit for standard maintenance



WARRANTY

Henkelman Inc offers a warranty of 1 year on labor and 3 years on parts. For full

DATE

APPROVAL



HENKELMAN INC.
493 W Fullerton Ave
Elmhurst IL, 60126

Sales and technical support
P +1 331 979 2013
F +1 630 359 3875
E info@henkelmanusa.com

VACUUM PACKAGING MACHINE POLAR 2-40 COMBIVAC - SPEC SHEET

VACUUM PACKAGING MACHINE POLAR 2-40 COMBIVAC – SPECS

VACUUM PACKAGING MACHINE POLAR 2-40 COMBIVAC – SPEC SHEET

DIMENSIONS

In inches

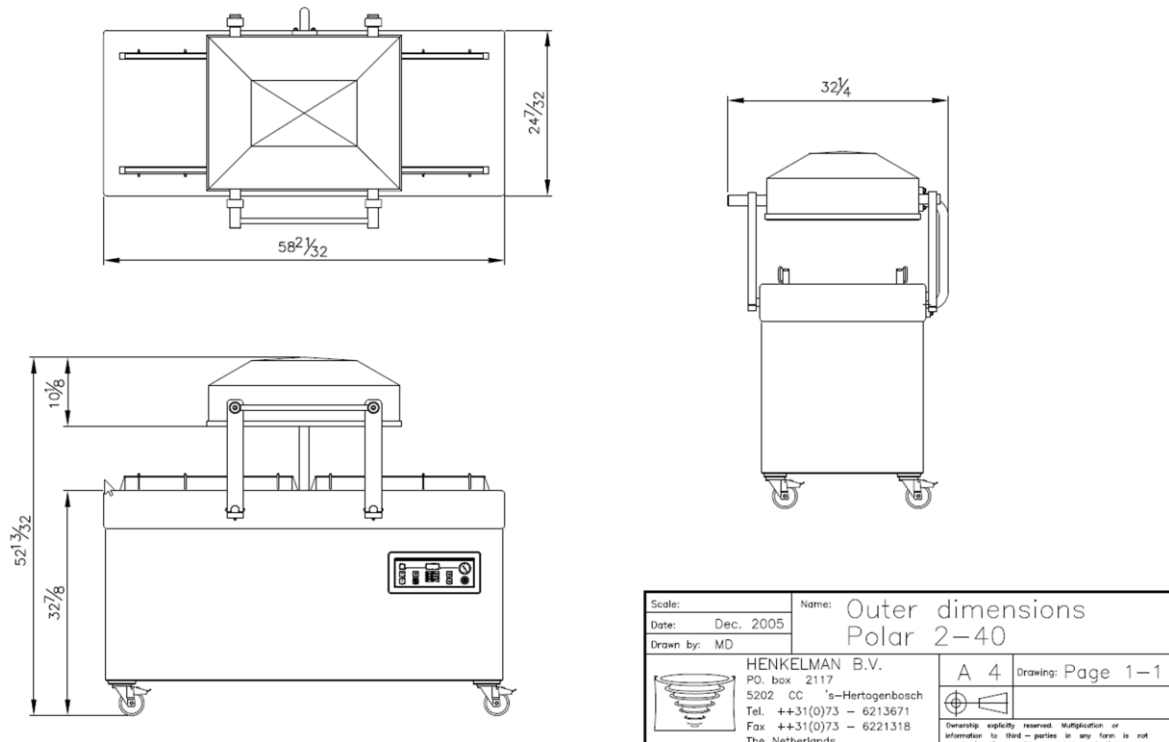

Model	Dimensions (inches)		Volts	Amps	Hz	Pump capacity	HP	Plug	Weight (lbs)
	Chamber L x W x H (usable space in inch)	Machine L x W x H (in inch)							
Polar 2-40	15.7 x 24.4 x 9.4	32.3 x 58.7 x 52.9	208- 220V	20	60Hz	2,780 cf/h (75 m3/h)	3.2	NEMA 14-50P 50A/25 0V	684



3 pole, 4 wire grounding 3 x 208 Volt

 ORIGINAL
HENKELMAN
VACUUM SYSTEMS
<https://www.henkelman.com/us>

HENKELMAN INC.
493 W Fullerton Ave
Elmhurst IL, 60126

Sales and technical support
P +1 331 979 2013
F +1 630 359 3875
E info@henkelmanusa.com