



RÔTISSERIE

STAR-CLEAN MINI-CONCEPT

8.720i2LSP8

STAR-CLEAN MINI-CONCEPT

Space-, time-, and energy-saving Mini Rotisserie Concept with assisted cleaning. Boost impulse sales and maximize food presentation during the cooking process.

The MINI-CONCEPT: Optimization of space with a self-service display

Heated display with dual level stainless steel shelves angled at 10° for grab-and-go convenience. Featuring digital electronic temperature control. Mounted on castors with brakes.

Topped by a programmable STAR-CLEAN convection rotisserie with baskets or chicken spits. 6 pre-set recipes via digital controls. Pre-heat, hold and cool-down cycles.

Wash program cycle removes internal grease and guarantees a quick return to service with low labor impact. Safely dispose of hot grease in optional tub lined with disposable heat--proof liner.

Designed for your operators to load and unload with rear door reach-in and pass-through configurations. Front or rear control options.





EXPAND MENUS

A variety of baskets and skewers easily slide into place to cook pork loin, turkey breast, meatloaf, ribs, vegetables, and more.

See [video](#).

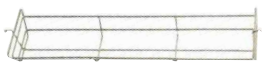

8.720i2LSP8

<p>BALD720 Chicken baskets standard</p>		<p>BAP720 Small cuts basket</p>		<p>BAB720 Spit for large pieces</p>	
<p>PD720 Stainless steel top tray</p>		<p>BCRA720 Spatchcock chicken basket</p>			

Front view
Customer side

Side view

Rear view
Service side

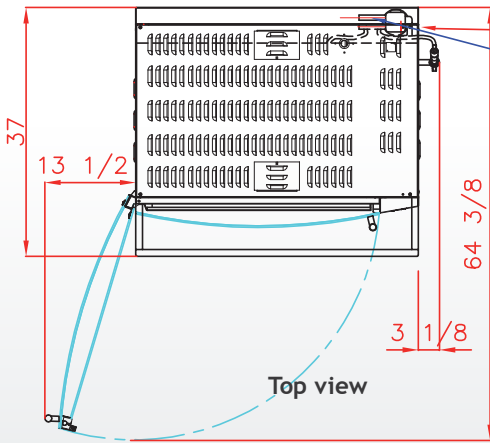
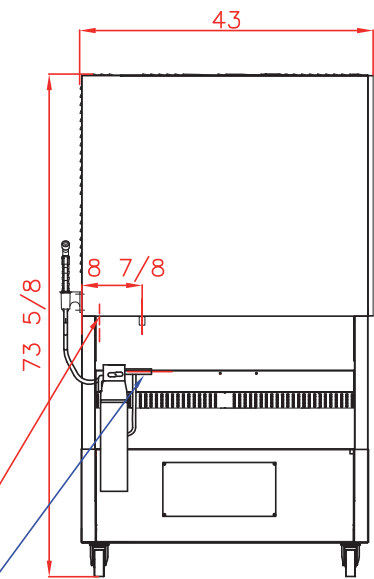
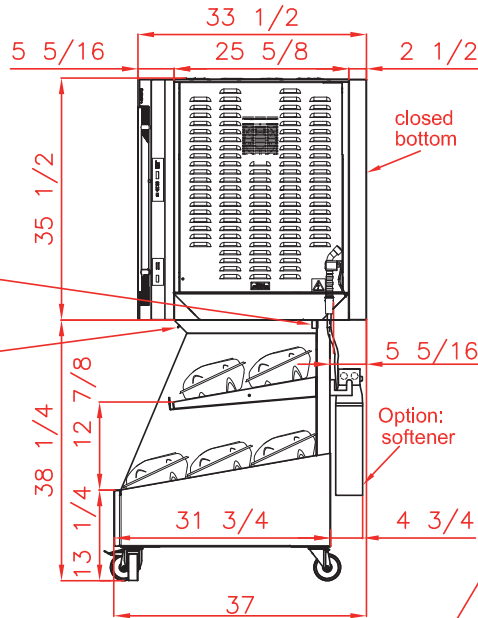
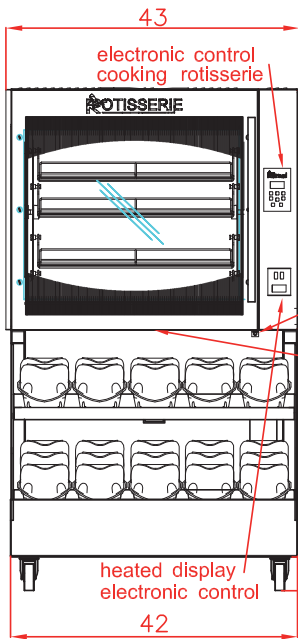

Electrical supply
208-240V~60Hz

Cold water
inlet softened Ø15/21
drain Ø1



8.720i2LSP8

Revised:
March 2021

SPECIFICATIONS

Capacity roasted chickens	32-40 chickens, 8 baskets/spits
Display capacity	25 chickens
Power supply	208-240V~60Hz; 3-phase + Ground
Electrical power	53 Amps; 11 kW
Weight and size (HxDxW)	618 lbs; 73 5/8 x 37 x 43 inches
Shipping weight and size	750 lbs; 81 1/8 x 40 5/8 x 44 1/2 inches
Warranty	1 year parts and labor

DISTRIBUTOR / AGENT

Rotisol France, Inc.
415 W. Walnut St. Gardena, CA 90248
info@rotisolusa.com
Ph: 310 671 7254
800 651 5969