

DESIGNER LINE SANDWICH UNIT

Model: D32N8C-D

Natural Refrigerant R-290 Model

Designer Line

32" Cutting Top Sandwich Unit Refrigerator with Drawers - 8 Pans

Stainless steel front, top and end panels and interior.



Options and Accessories

(upcharge and lead times may apply)

Stainless steel back	Rear mounted cutting board
Overshelves (single or double)	Composite cutting board
Drawer locks	Flat insulated night cover
Crumb catcher	Vision panel lid
Casters	Modified pan openings

Consult factory for other model configurations, options and accessories.

Project Name:

Model Specified:

Location:

Item No:

Quantity:

AIA #:

SIS #:

Standard Model Features

REFRIGERATION SYSTEM

Performance rated refrigeration system

Natural, environmentally safe,
high efficiency R-290 refrigerant¹

Unique air flow distribution allows
pan product to maintain 33° - 41°F

Automatic, hot gas condensate evaporator

Non-corrosive, plasticized fin evaporator coil

Easily serviceable, back mounted compressor

CABINET ARCHITECTURE

2" non-CFC polyurethane foam insulation

Smooth, polished chrome drawer handles

Stainless steel roll out drawers

Magnetic snap in Santoprene™ door gaskets

19" deep, full length nylon cutting board

Insulated lid

Completely enclosed, vented and removable case back

6" adjustable, stainless steel legs

MODEL FEATURES

Off-cycle defrost

Electronic controller with digital display & hi-low alarm

(8) ½ size recessed pans, 4" deep

Removable interior tub below pans

¹ R-290 refrigerant meets all federal and state regulatory requirements.

Continental[®]
Refrigerator

Toll-Free: 800-523-7138
Phone: 215-244-1400
Fax: 215-244-9579

539 Dunksferry Road
Bensalem, PA 19020
www.continentalrefrigerator.com

APPROVAL:

Model Specifications

DIMENSIONAL DATA

Net Capacity (cubic feet)	9.0 (253 cu l)
1/6 Size Pans (4" deep)	8
Width, Overall (inches)	32 (813 mm)
Depth, Overall (inches) (including cutting board & bumpers)	38 1/4 (972 mm)
Depth, Cutting Board (inches)	19 (483 mm)
Height, Overall (inches) (including 6" legs)	43 1/4 (1099 mm)
Number of Drawers (two tier)	2

REFRIGERANT DATA

Condensing Unit Size (H.P.)	1/5
Capacity (BTU per hour)*	1625

ELECTRICAL DATA

Voltage (International)	115/60/1 (220/50/1)
Total Amps (International)	2.46 (1.85)
10 ft. Cord/Plug [attached] (International)	Yes (No)

SHIPPING DATA

Weight (pounds)	236 (107 kg)
Height - Crated (inches)	43 1/4 (1099 mm)
Width - Crated (inches)	40 (1016 mm)
Depth - Crated (inches)	37 1/4 (946 mm)

DRAWER PAN CONFIGURATIONS

Two Tier: (1) 12 x 20 x 6 pan per drawer
or (1) 1/2 size x 6 & (2) 1/3 x 6 pans per drawer

* Rating @ +25°F evaporator, 90°F ambient
Figures in parentheses reflect metric equivalents rounded to the nearest whole unit.



Equipped with one NEMA-5-15P Plug
(varies by country)

Continental[®]

Refrigerator

Toll-Free: 800-523-7138
Phone: 215-244-1400
Fax: 215-244-9579

539 Dunkserry Road
Bensalem, PA 19020
www.continentalrefrigerator.com

Due to our continued efforts in developing innovative products, specifications subject to change without notice.



© Copyright 2021. Continental Refrigerator.
A Division of National Refrigeration & Air Conditioning Products, Inc.

Model Plan Views

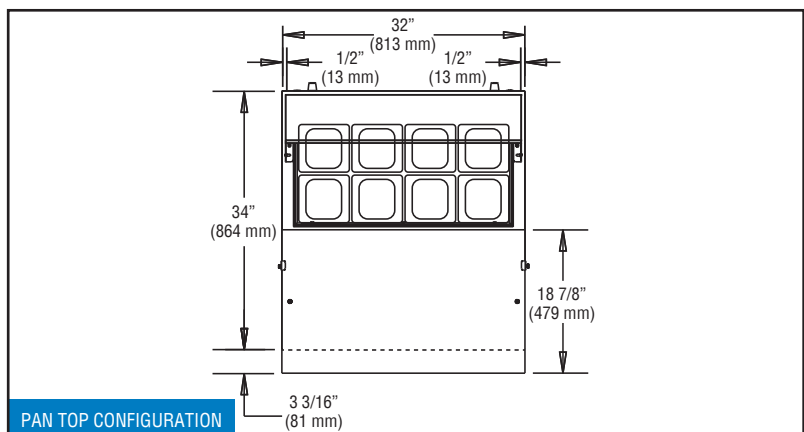
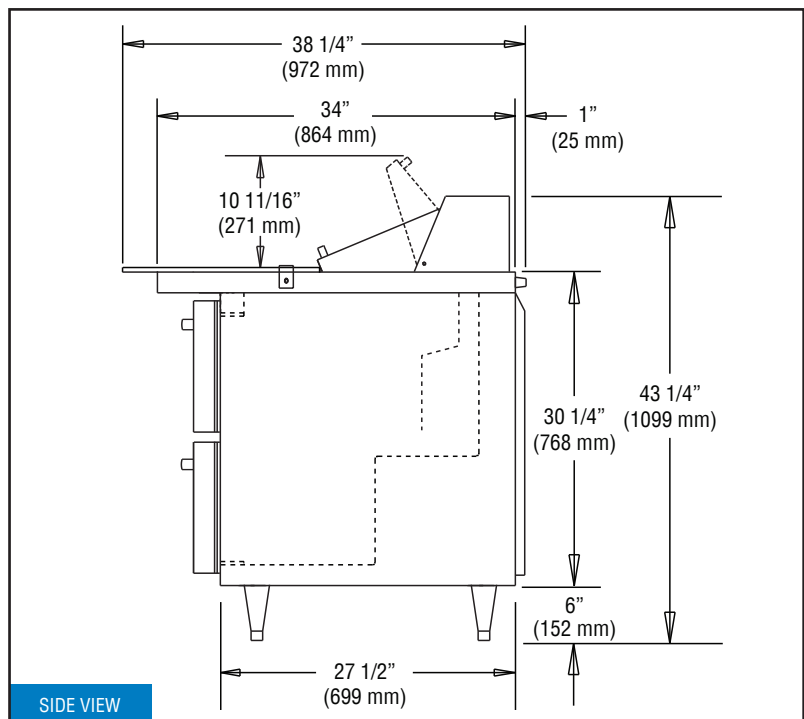
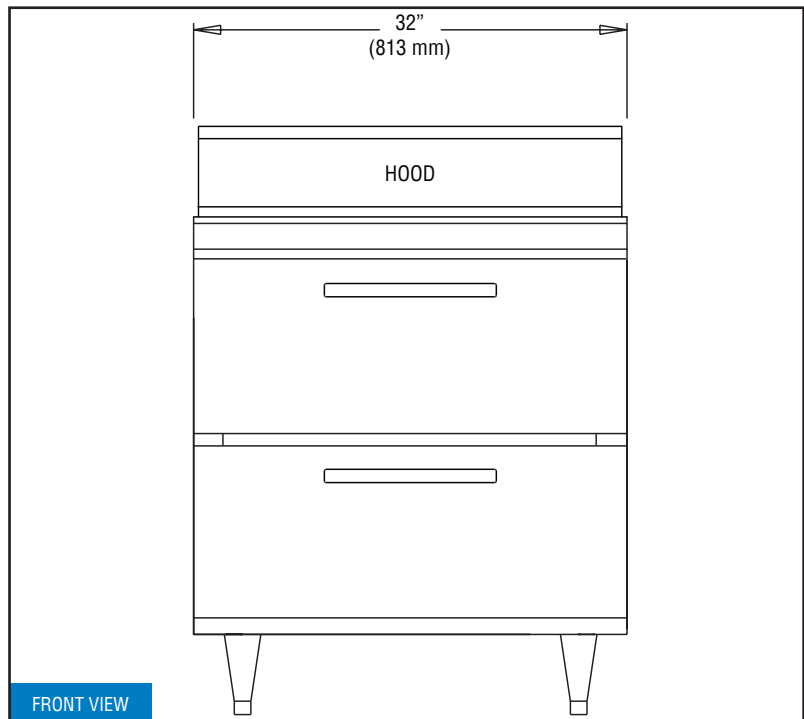

REVISED: 6/9/2022