

ELECTRIC TILT BRAISING PAN 34 GALLON WITH MIXER - 12.6kW, 5.8PSI - HEATING WALLS



UCBTE034ACV1

General Functional Features

- Heating by means of armoured elements in INCOLOY-800 alloy controlled by electronic board
- Temperature control by system with two probes (product/bottom)
- Heating tank walls by using 3 band heaters, which can be activated from the bottom up, controlled by an electronic control panel
- Pressure cooking with automatic system for eliminating air from the cooking container (for cooking with saturated steam) and automatic steam condensation after cooking to allow fast and safe lid opening without steam dispersion in the room
- Automatic mixing device with three arms and PTFE scrapers, completely removable to make cleaning easier, with regulation directly from the control panel according to the product to be processed
- Electronic control by means of multifunctional keyboard with Touch Screen 7" and easy and clear messages
- USB connection to download HACCP data, update the software and load cooking programs
- Ability to interrogate the machine using communication protocol MODBUS over RS485 serial interface
- Connection for power economizer

Panel Board Functions

- On/off switch
- Resistive 7" touch screen
- Keys to turn on/off the mixer and move basin
- Selection of 8 different cooking modes, with working temperature setting
- Possibility of cooking with tilted basin (up to 15°)
- Cooking type and time setting
- Cooking in "Manual" mode
- Cooking in "Program" mode
- Creating and editing multiphase cooking programs, setting for each phase: type of cooking; cooking parameters (temperature and time); mixer settings; settings for heating walls and possibility to insert text messages
- Wall temperature settings (range 122-266° F) and 3 levels for heating walls
- Speed setting/adjustment (clockwise and counterclockwise) rotation times and mixer pause times
- Possibility to activate mixer at minimum speed during tank tilting to facilitate product pouring
- Tank water load setting (hot up to 140° F/cold) with automatic liter measurements
- Control for tilting and return of cooking tank from Touch Screen or keyboard
- Delayed cooking setting with date, time, and programming cycle
- Language settings Touch Screen
- Input of different units of measurement (° C/° F, Liters/gallons, etc)

Display/Signal

- Display type of cooking, temperature probes used and set temperature
- Heating operating visual alarm
- Time to end of cycle display
- Tank pressure display
- Reporting lid locking and condensing time during cooking under pressure
- Display tank out of position for cooking
- Audible/visible warning of mixer program start
- Signaling tap position, managing water in the tank
- Signal of lid and cock position during vat tilting
- Thermostat intervention safety signaling
- Self-diagnostics

Safety System

- Emergency button
- Blocking of heating for excess of temperature with manual resettable safety thermostat
- Mechanical lid opening lock with tank under pressure
- Lid safety valve
- Heating interruption during vat tilting

OPTIONS & ACCESSORIES AT ADDITIONAL COST

- | | |
|---|--|
| <input type="checkbox"/> CADE0010 - CLEANING SHOWER | <input type="checkbox"/> DAPF0010 - SET FEET |
| <input type="checkbox"/> D150 - KIT WHEELS | <input type="checkbox"/> PAF0702 - PERFORATED STRAINER |

STANDARD CONSTRUCTION SPECIFICATIONS

Cooking vessel in stainless steel AISI 304 (bottom thickness 12 mm and wall thickness 3 mm). Vessel with electric tilting on front part

Lid in stainless steel AISI 304 (thickness 20/10), with double cover, with ergonomic handle, reinforced with locking system at 4 points on sliding shafts and lever type control bolts with blocking of opening under pressure. Alimentary silicone gummy gasket with only one jointing point. Balanced by means of gas springs

Self-supporting frame in stainless steel AISI 304 (thickness 30-40/10)

Outer cover in stainless steel AISI 304, fine satin finish (thickness 12-15/10)

Adjustable feet in stainless steel AISI 304 to ensure levelling, with removable cover for cleaning operations

Fast accessibility to the main functional parts (electronic card, fuses, thermostats...) only removing the frontal panels

Protection level IPX5



Approval Notes: _____

* REG. 0 ; + 1 5/8"

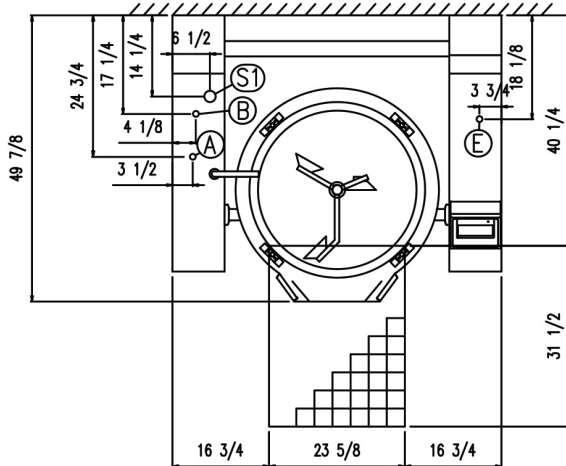
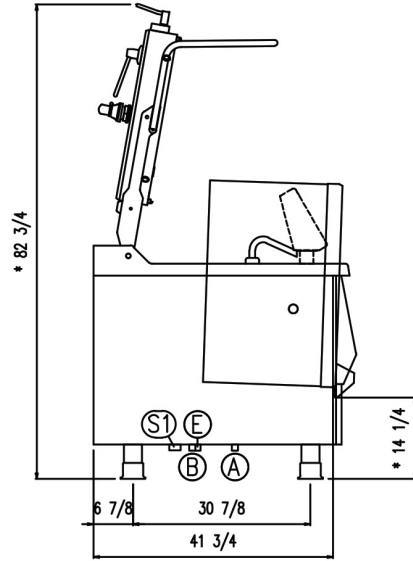
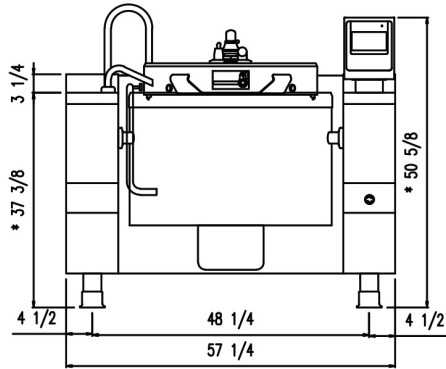

TECHNICAL SPECIFICATIONS

DIMENSIONS						Weight	Capacity
Width	Depth	Height	Vessel Diameter	Vessel Height	Cooking Vessel Surface		
57 1/4"	49 7/8"	50 5/8"	27 1/2"	16 1/2"	589 in ²	992 lb	36 gal

Mixer			UTILITIES						
TORQUE	POWER	SPEED RPM	HOT WATER INLET (A)	COLD WATER INLET (B)	WATER PRESSURE	CONDENSATE DRAIN PRESSURE (S1)	STD VOLTAGE (E)	ELECTRIC POWER	CURRENT
191 Nm	0.37 kW	6-18	3/4"	3/4"	25-50 PSI	1"	3 PHASE 208V~ 60Hz	16.20 kW	45.0 A
							3 PHASE 220-240 V~ 60Hz	17.40 kW	41.9 A

**INTENDED FOR COMMERCIAL USE ONLY.
NOT FOR HOUSEHOLD USE.**

