

MARINE GRADE THE BETA 450 ELECTRIC

ELECTRIC FLOUR TORTILLA PRESS AND OVEN

Roll up to the challenge to make 450 tortillas per hour and roll away to conserve space. The Marine Grade Beta 450 Electric has a small footprint and is mobile. Save labor and time with this one person operation. It provides consistent, freshly made flour tortillas and flatbreads in an eye catching carousel display that guarantees to deliver a presentation.

MODEL 9AEV-12SS PRESS

240V

13Amps

Heating Element: 3120 Watts

Dimensions: L 20.6" x W 13.6" x H 16.9"

Dimensions: L 66cm x W 36cm x H 44cm

Weight: Approx. 70 lbs./32 Kg

Tortilla Production: Up to 450 per hour

Tortilla Diameter: 4"/10cm to 7"/18cm



Plug:
NEMA 6-20P
(250V-)



Receptacle:
NEMA 6-20R
(250V-)

MODEL 5-12SS OVEN SPEC

240 Volts*

18 Amps / 4800 Watts

Dimensions: L 33" x W 31" x H 44"

Dimensions: L 84cm x W 79cm x H 112cm

Patent: 61/398,016 pending

Shipping Weight: Approx. 250lbs. / 114 kg

*You will need 240V to fully utilize the capabilities of the Marine Grade Beta 450E. Less than 230V requires installation of Buck and Boost



Plug:
NEMA 10-20P
(250V ~)



Receptacle:
NEMA 10-20R
(250V ~)



*Tortilla production may vary due to operator experience, diameter and thickness of tortillas.

*BE&SCO equipment is solely intended for use in a commercial facility.



200 Lombrano St · San Antonio, TX 78207 USA
Office: (210) 734-5124 · Fax: (210) 737-3925
Toll Free: 1-800-683-0928
Email: sales@bescomfg.com · Website: www.bescomfg.com
Visit our website to view video www.bescomfg.com



Revised
03/05/2020

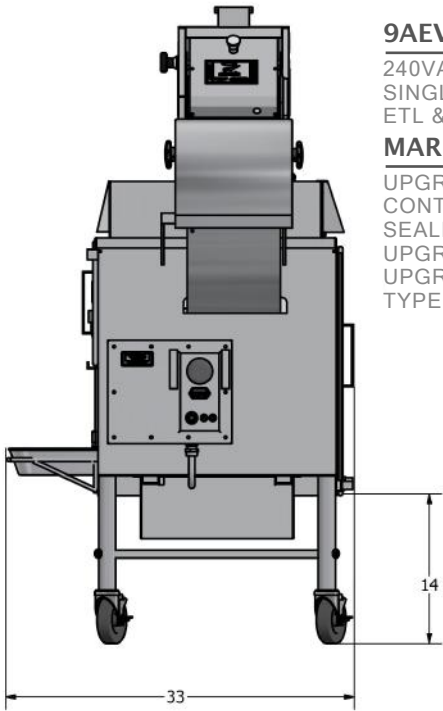

9AEV-12SS PRESS SPECS:

240VAC, 13AMPS
 SINGLE PHASE, 60HZ
 ETL & NSF LISTED

MARINE GRADE HIGHLIGHTS:

UPGRADED TYPE 316L STAINLESS STEEL
 CONTROL PANEL ON EXIT SIDE OF OVEN
 SEALED ELECTRICAL CONTROL BOX
 UPGRADED TYPE 316L MOTOR CAMS/FOLLOWERS
 UPGRADED TEMPERATURE CONTROL SYSTEM
 TYPE 316L HEX HEAD HARDWARE

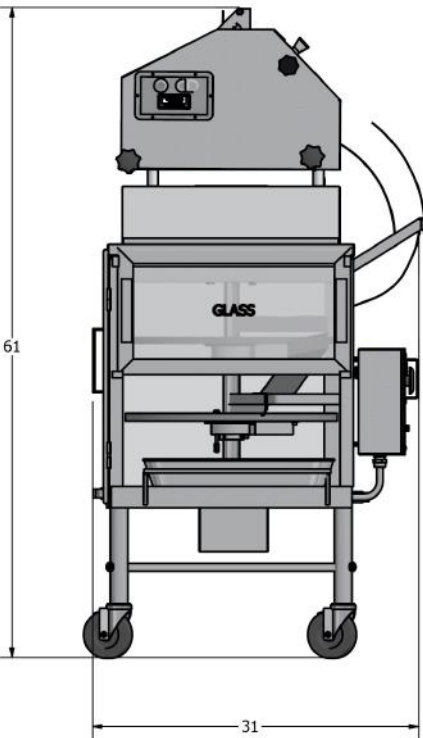
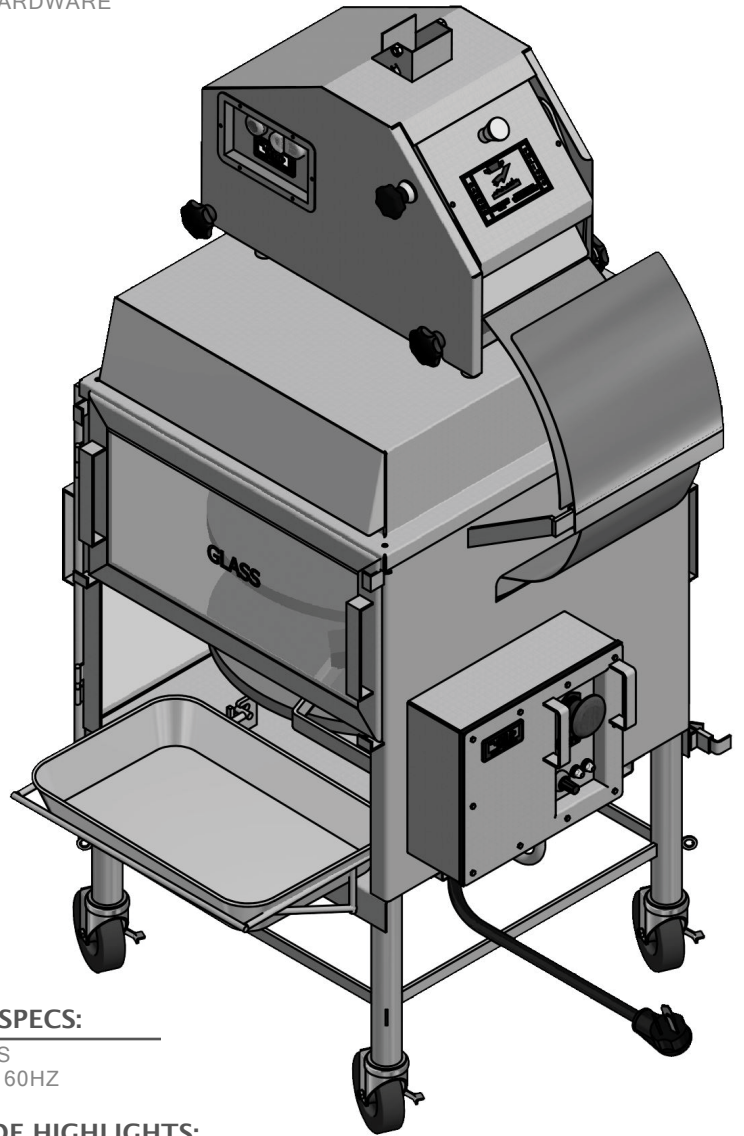

5-12SS OVEN SPECS:

240VAC, 18AMPS
 SINGLE PHASE, 60HZ
 ETL LISTED

MARINE GRADE HIGHLIGHTS:

UPGRADED TYPE 316L STAINLESS STEEL
 MARINE GRADE CASTERS (4 LOCKING)
 SINGLE CONSOLIDATED SEALED CONTROL BOX
 MARINE GRADE (WASHDOWN) MOTOR
 EASILY CLEANABLE LOUVERS ON VENT HOOD
 MARINE GRADE ELECTRICAL SLIP RING
 TYPE 316L HEX HEAD HARDWARE
 MACHINE RAISED TO 14" HEIGHT*
 *MFG SUGGESTS SECURING MACHINE DUE TO RASIED HEIGHT