

DESIGNER LINE PASS THRU FREEZER (0°)

Model: D2FENPT

2-Section Extra-Wide Pass-Thru Freezer

D2FENPT - Stainless steel front, aluminum end panels and interior
D2FENSAPT - Stainless steel exterior, aluminum interior
D2FENSSPT - Stainless steel exterior and interior
Designed to maintain NSF-7 temperatures in 100°F ambient.



Options and Accessories

(upcharge and lead times may apply)

Additional epoxy coated steel shelves	Custom laminates
Chrome or stainless steel shelves	Special electrical req. (consult factory)
Casters	Correctional Facility Options
Rehinging of doors (consult factory)	<ul style="list-style-type: none"> One way security screws
Half doors	<ul style="list-style-type: none"> Locking hasp (lock not included)
Pan slide assemblies	<ul style="list-style-type: none"> Stainless steel mesh cover Coverless hinges

Consult factory for other model configurations, options and accessories.

Continental[®]
Refrigerator



Project Name:

Model Specified:

Location:

Item No:

Quantity:

AIA #:

SIS #:

Standard Model Features

REFRIGERATION SYSTEM

Self contained, performance rated "plug" refrigeration system

Natural, environmentally safe, high efficiency R-290 refrigerant¹

Refrigeration system is readily accessible on top of cabinet, separate from the "food zone"

Automatic, hot gas condensate evaporator

Expansion valve system

Standard operating temperature is 0 to -5°F and can be adjusted to operate as low as -10°F in a 90°F ambient.

CABINET ARCHITECTURE

3" non-CFC polyurethane foam insulation

Smooth, polished chrome workflow door handle

Cam action, lift off hinges

Self-closing door

Magnetic snap-in Santoprene™ door gasket

Cylinder lock in door

Heavy duty pilaster strips

Heavy duty, epoxy coated steel shelves

Adjustable 6" stainless steel legs

MODEL FEATURES

LED interior lighting

Electronic controller with digital display & hi-low alarm

Automatic electric defrost

Top and side air distribution ducts

Cabinet upper side panels and refrigeration "plug" system can be removed and reinstalled at job site

¹ R-290 refrigerant meets all federal and state regulatory requirements.

APPROVAL:

Model Specifications

DIMENSIONAL DATA

Net Capacity (cubic feet)	52 (1472 cu l)
Width, Overall (inches)	57 (1448 mm)
Depth, Overall (inches) (including handles)	35 3/8 (899 mm)
Depth (inches) (less doors)	32 (813 mm)
Depth (inches) (doors open 90°)	58 (1473 mm)
Clear Door Width (inches)	21 7/8 (556 mm)
Clear Door Height (inches)	58 5/8 (1489 mm)
Height, Overall (inches) (including 6" legs)	83 1/4 (2115 mm)
Number of Doors	4
Number of Shelves	6
Shelf Area (square feet)	40.8 (3.8 sq m)
Tray Slide Capacity (per section)	24

REFRIGERANT DATA

Condensing Unit Size (H.P.)	1
Capacity (BTU per hour)*	2470

ELECTRICAL DATA

Voltage (International)	115/60/1 (220/50/1)
Feed Wires (including ground)	3
Total Amps (International)	9.7 (6.2)
Defrost Amps (International)	5.2 (2.6)
10 ft. Cord/Plug [attached] (International)	Yes (No)

SHIPPING DATA

Height - Crated (inches)	85 1/2 (2172 mm)
Width - Crated (inches)	64 (1626 mm)
Depth - Crated (inches)	42 (1067 mm)
Volume - Crated (cubic feet)	133 (3766 cu l)
Weight Std - Crated (pounds)	575 (261 kg)
Weight SS - Crated (pounds)	605 (274 kg)

* Rating @ +25°F evaporator, 90°F ambient
 Figures in parentheses reflect metric equivalents rounded to the nearest whole unit.



Equipped with one NEMA-5-15P Plug
 (varies by country)

Model Plan Views

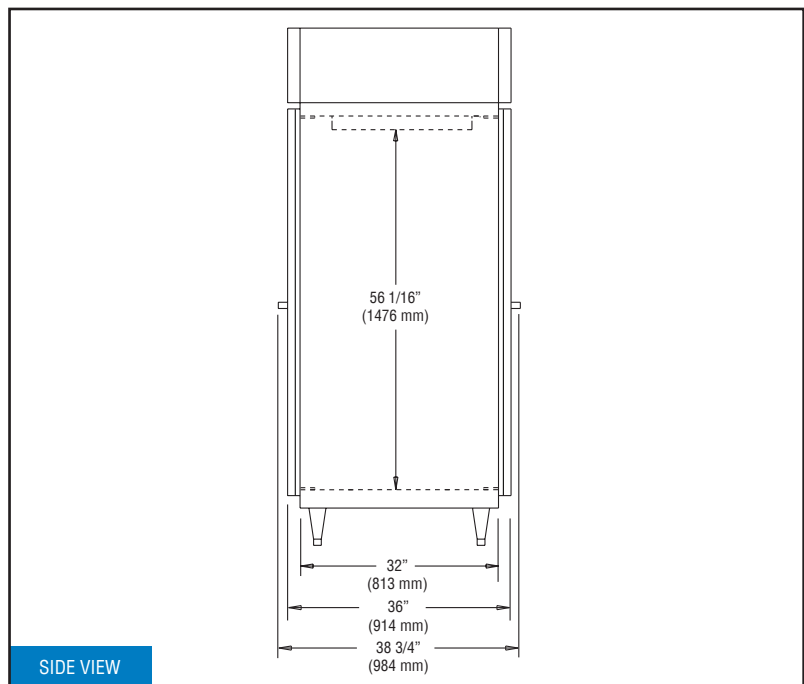
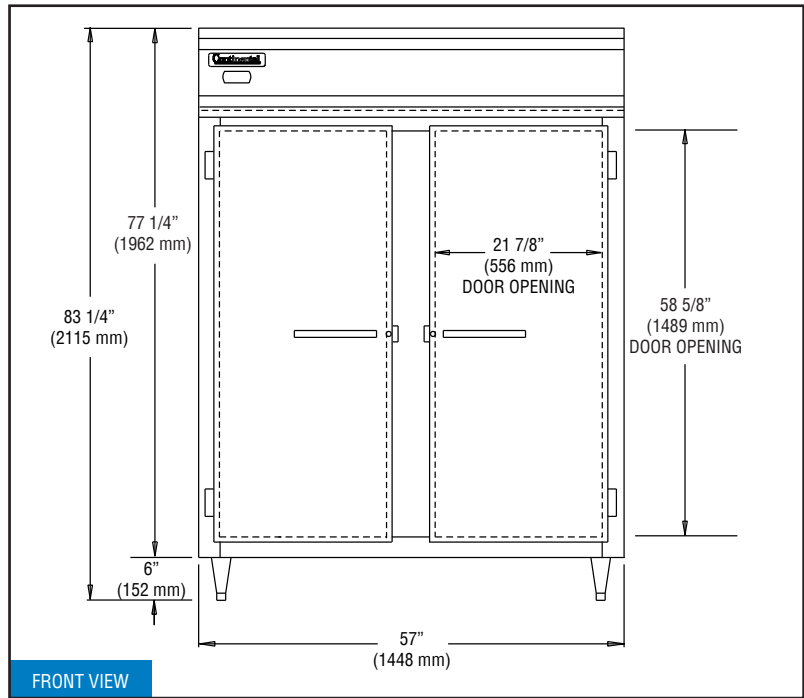

Toll-Free: 800-523-7138
 Phone: 215-244-1400
 Fax: 215-244-9579

539 Dunksferry Road
 Bensalem, PA 19020
www.continentalrefrigerator.com

Due to our continued efforts in developing innovative products, specifications subject to change without notice.



PROUDLY
 DESIGNED & ASSEMBLED
 IN THE U.S.A.

Intertek

© Copyright 2021. Continental Refrigerator.
 A Division of National Refrigeration & Air Conditioning Products, Inc.

REVISED: 2/13/24