

Endurance Pro X2M

DP2010M

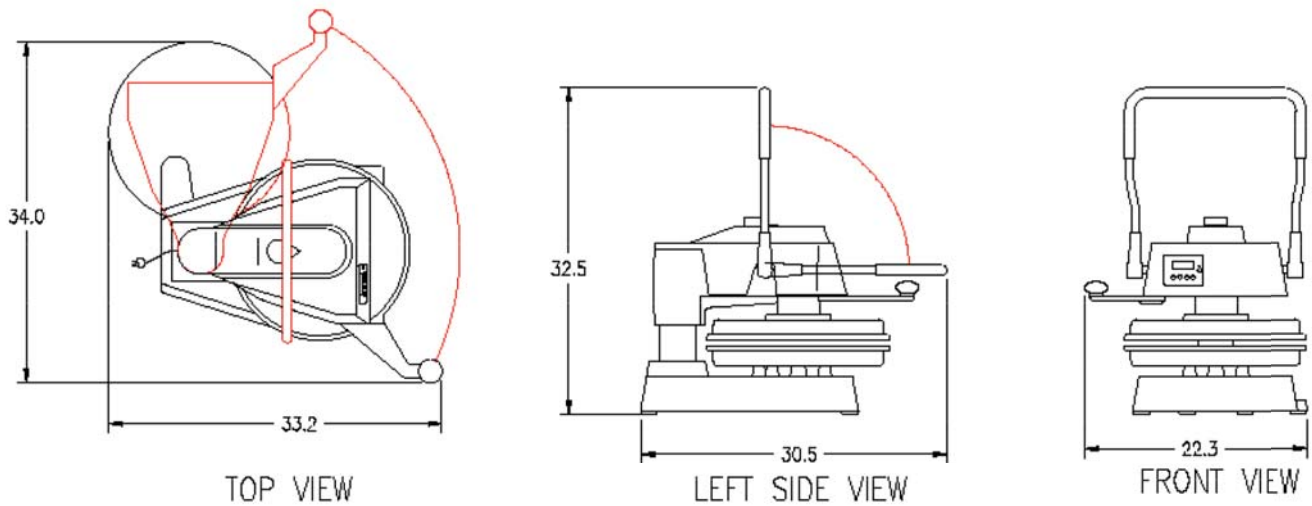

Equipment Details

| | | | |
|---------------------|-----------|-----------------|-------------|
| Temperature Control | Yes | Pies Per Hour | 200+ |
| Maximum Heat | 450F/232C | Shipping Weight | 175lbs/79kg |
| Programmable Timer | Yes | Machine Weight | 140lbs/63kg |
| Thickness Control | Yes | Voltage | 208/220 |
| ON/OFF Switch | Yes | Wattage | 4600/5146 |
| Power Cord Length | 72" | Amps | 22.1/23.4 |



PROLUXE™

HELPING COMMERCIAL KITCHENS
PRODUCE GREAT FOOD FASTER

CORPORATE HEADQUARTERS
20281 HARVILL AVE. PERRIS, CA 92570

ADVICE AND SUPPORT
1-800-624-6717

NEW!

The Next Generation of Dough Pressing

Simplify your operation by pressing multiple size pizzas with interchangeable molds on our most popular dual heated dough press. Easily press from 8 inch to 16 inch pies in under 10 seconds with all the benefits of dual heated platens.

Endurance Pro X2M

Dual Heat Semi-Automatic Dough Press
with Mold Inserts
DP2010M



The Most Productive Press Ever

The dual heat platens par bake the dough to decrease cook times and increase hold time. Change out your molds in seconds to offer more sizes.



150-250 PIZZAS PER HOUR



DUAL HEATED PLATENS LIFETIME LIMITED WARRANTY



INTERCHANGEABLE MOLDS (8-16 IN. DIAMETER)



PRESSED IN SECONDS