



Job:

Item No.

## Countertop Oven MODEL: NCOT5

### FEATURES & BENEFITS

- Programmable Touchscreen Controls
- Temperature up to 475°F (246°C)
- Door switch cutoff for fan blower
- Stainless steel construction
- Two Speed Fan
- 4" adjustable legs (102 mm)
- Press-fit removable door gasket for easy cleaning
- One-handed door handle operation
- Cool touch door with dual thermal wide view glass
- Lift up removable side racks
- Two year parts and one year labor warranty

### OPTIONS & ACCESSORIES

- Wire Shelf (98-1227-A)
- Equipment Stand (98-9450)

### DIMENSIONS & SHIPPING WEIGHT

29 1/4"W X 27 13/16"D X 26 11/16"H  
(743 mm X 706 mm X 677 mm)  
180 lb (82 kg)

### FINISH

Stainless Steel

### STANDARD PRODUCT WARRANTY

One Year Labor & Two Year Parts



### ELECTRICAL SYSTEM

#### 1 Phase:

- 208V - 21 A - 4 kW - 60 Hz - 2 wires + ground
- 240V - 18 A - 4 kW - 60 Hz - 2 wires + ground

### CAPACITY

5 Half Size Sheet Pans (13" x 18" - 330mm x 457mm)  
Shelf Spacing: 3 1/8" (89 mm)

### SHORT SPECIFICATION

Countertop Oven, Electric, Programmable Touchscreen Control, 4" Adjustable Legs, Left Hinge, Cool To Touch Door, Stainless Steel Construction Interior & Exterior, Slam Cam Handle, Stackable Without Hardware, 4 kW, ETL & NSF Certified



# DRAWINGS

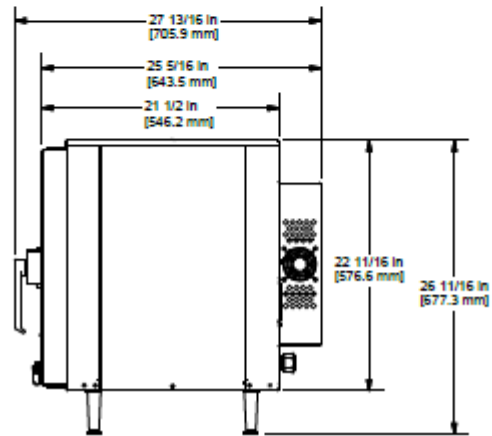
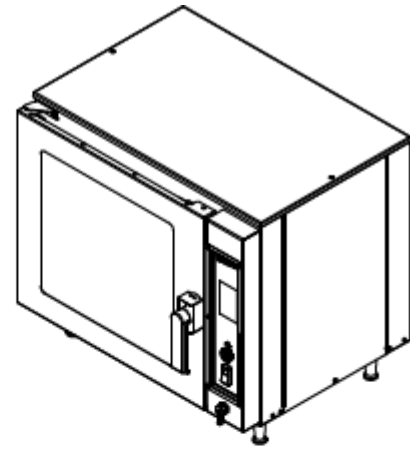
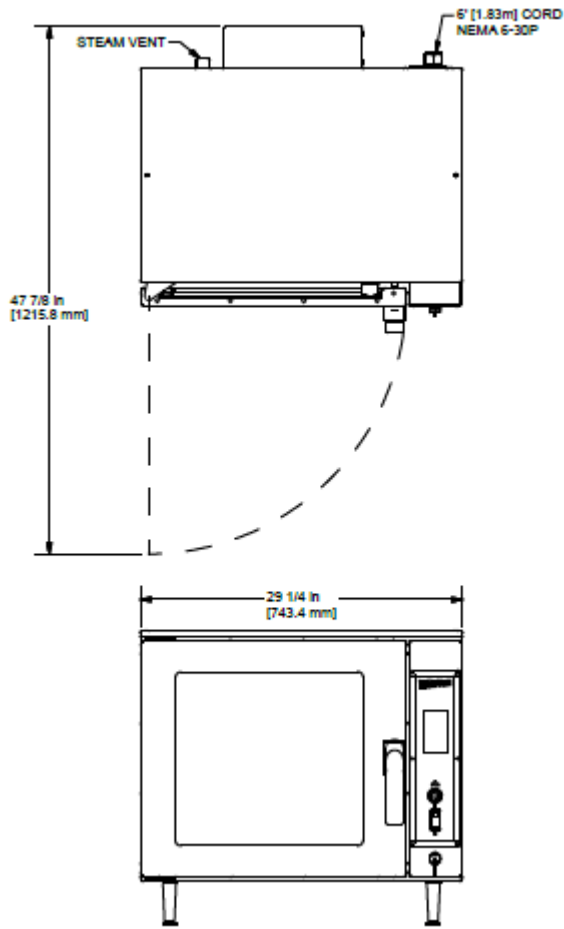

## PRODUCTION CAPACITY

Product (Fresh State)	Bake Time	Bake Temp (°F)	Bake Temp (°C)	Quantity Produced
9" Cakes	18 - 22 minute	350	177	15
9" Pies	30 - 35 minute	375	190	10
Bagels (8 per half pan)	15 minute	350	177	n/r
Dinner Rolls (8 per half pan)	15 - 18 minute	350	177	128
Sub Rolls 12" (5 per half pan)	15 - 18 minute	350	177	100
French Baguettes (5 per pan)	20 - 25 minute	350	177	n/r
Croissants (15 per pan)	12 - 15 minute	350	177	n/r
Muffins (12 per pan)	18 - 22 minute	325	163	180
Muffins (24 per pan)	18 - 22 minute	325	163	n/r
9" Quiches	30 - 35 minute	350	177	15
Cookies (9 per half pan)	8 - 10 minute	300	149	270
Danish (7 per pan)	12 - 15 minute	350	177	175
Biscuits (7 per half pan)	8 - 10 minute	350	177	210
Bread (4 strapped pan)	30 - 35 minute	375	190	n/r
Cinnamon Rolls (8/half pans)	15 - 18 minute	325	163	160
Brownies (16 1/2oz box)	12 minute	350	177	25

\*Capacities are per hour



5600 13th Street  
Menominee, MI 49858  
sales@nu-vu.com  
(800) 338-9886 Toll Free  
(906) 843-4401 Phone  
(906) 863-5889 Fax  
www.nu-vu.com

**SPECIFICATIONS SUBJECT TO CHANGE WITHOUT NOTICE  
KCL & REVIT DRAWINGS UPON REQUEST**

Rev 1—2/16/2017