

# SHALLOW DEPTH BASE MODEL SANDWICH UNIT

## MODEL: RA60SN12-D

Natural Refrigerant R-290 Model

### 60" Shallow Depth Base Model Sandwich Unit with Drawers

Heavy gauge #300 Series stainless steel top, stainless steel front and end panels, galvanized steel rear and grill and aluminum interior.



## Options and Accessories

(upcharge and lead times may apply)

Stainless steel interior	Condensing unit left (standard on right)
Stainless steel back	Door & drawer locks
Stainless steel shelves	Pan Slides
Additional epoxy coated steel shelves	Front Breathing
Overshelves (single or double)	Adjustable legs
Drawer in lieu of door section above the condensing unit*	

Consult factory for other model configurations, options and accessories.

\*Drawer section above condensing unit holds (4) 6 x 6 2/3 x 6 pan.

TWO TIER (larger section): (1) 12x20x6 pans per drawer

TWO NARROW: (4) 6 x 6 2/3 x 6 pan per drawer



Toll-Free: 800-523-7138  
Phone: 215-244-1400  
Fax: 215-244-9579

539 Dunksferry Road  
Bensalem, PA 19020  
www.continentalrefrigerator.com

Project Name:

Model Specified:

Location:

Item No:

Quantity:

AIA #:

SIS #:

## Standard Model Features

### REFRIGERATION SYSTEM

- Performance rated refrigeration system
- Natural Refrigerant R-290 Model
- Unique forced air design utilizes fans (approx. every 12") across the entire back of unit for even distribution of cold
- Automatic, hot gas condensate evaporator
- Non-corrosive, plasticized fin evaporator coil
- Easily serviceable, slide out condensing unit
- Expansion valve system

### CABINET ARCHITECTURE

- 2" non-CFC polyurethane foam insulation
- Smooth, polished chrome door handles
- Spring loaded, self closing doors
- Magnetic snap in Santoprene™ door gaskets
- Heavy duty, epoxy coated steel shelf
- Completely enclosed, vented and removable rear and side grills
- 5" casters

### MODEL FEATURES

- Electronic control, off cycle defrost
- Refrigerated section with door above the condensing unit
- Field rehingeable doors

<sup>1</sup> R-290 refrigerant meets all federal and state regulatory requirements.

**NOTE:** Models come standard with a door over the condensing unit. A drawer over the condensing unit is an option.

APPROVAL:

## Model Specifications

### DIMENSIONAL DATA

Net Capacity	15.2 cu. ft. (430 cu l)
Width, Overall	60 inches (1524 mm)
Depth, Overall (including handles & bumpers)	30 inches (764 mm)
Height, Overall (including 5" casters)	42 inches (1067 mm)
Shelf Area	0 Sq ft. (0 sq m)
Number of Shelves	0
Number of Doors	Full 0   Half 1
Interior Depth	24 inches (610 mm)
Interior Height	12.5 inches (318 mm)
Interior Height (above condenser)	12.5 inches (318 mm)
Interior Width	17 inches (432 mm)

### REFRIGERANT DATA

Condensing Unit Size	1/3+ H.P.
Capacity	2300 (BTU per hour)*

### ELECTRICAL DATA

Voltage (International)	115-60-1 (220-50-1)
Total Amps (International)	5.8 (3.9)
Defrost Amps	
10 ft. Cord/Plug [attached] (International)	Yes (No)

### SHIPPING DATA

Weight (pounds)	340 lbs. 154 kg
Height - Crated	43.75 in. (1111 mm)
Width - Crated	62 in. (1575 mm)
Depth - Crated	47 in. (1194 mm)

### DRAWER PAN CONFIGURATIONS

TWO TIER (larger section): (1) 12x20x6 pans per drawer  
TWO NARROW: (4) 6 x 6 2/3 x 6 pan per drawer

\* Rating @ +20°F evaporator, 120°F ambient  
Figures in parentheses reflect metric equivalents rounded to the nearest whole unit.



www.continentalrefrigerator.com

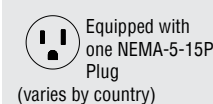

Equipped with one NEMA-5-15P Plug (varies by country)



© Copyright 2023. Continental Refrigerator.  
A Division of National Refrigeration & Air Conditioning Products, Inc.

## Model Plan Views

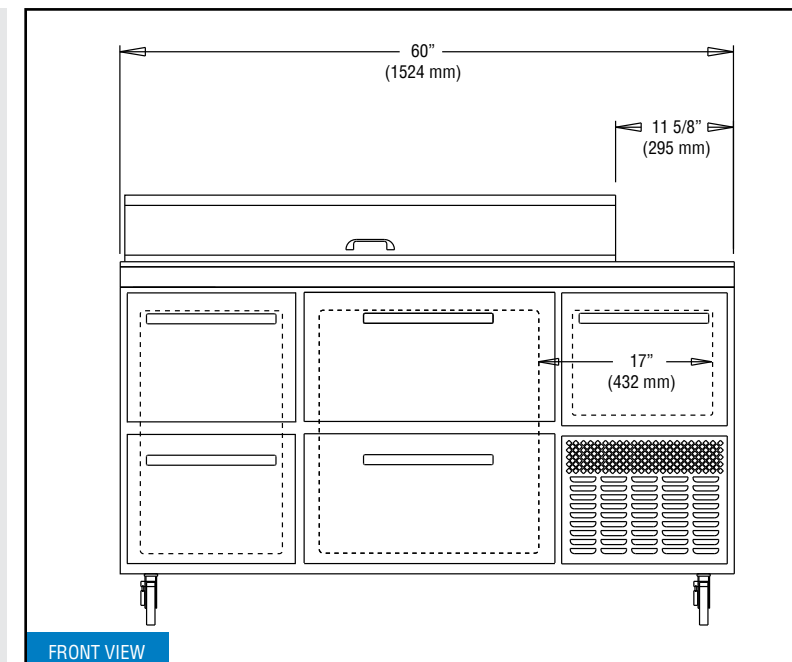

FRONT VIEW

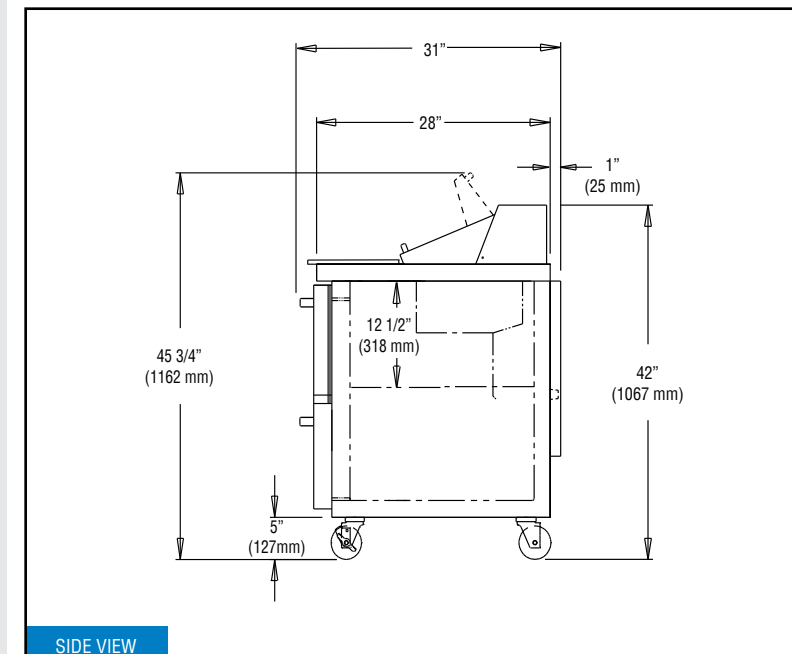

SIDE VIEW

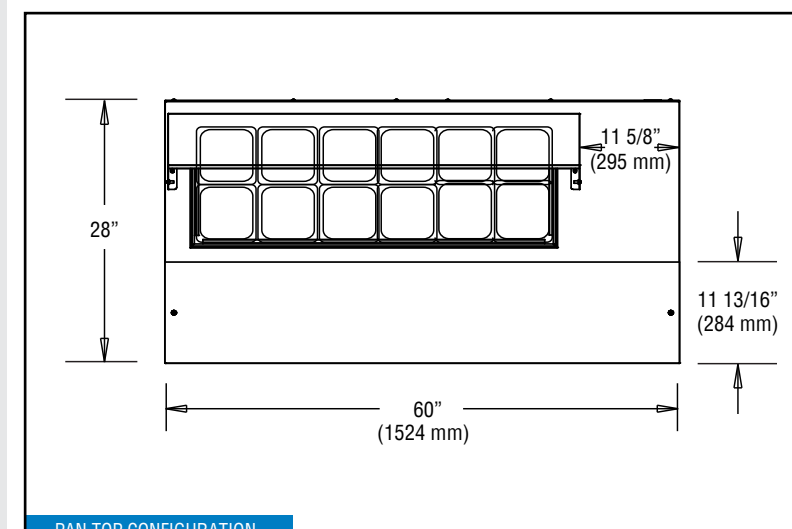

PAN TOP CONFIGURATION

Due to our continued efforts in developing innovative products, specifications subject to change without notice.

REVISED: 8/11/23