



Project: _____
 Location: _____
 Item #: _____ Quantity: _____
 Model #: _____

MODELS: IDC-VML12 IDC-VML15 IDC-VML18 Fish displays case Malaga series



VML15

General Strengths

- ✓ **Sanitation.** Quick ability to take off shelves for interior cleaning. Each cabinet has a drain at the bottom of the unit. When cleaning the unit make sure the drain hose is routed to a floor drain.
- ✓ **Control systems.** Higher precision in managing temperature settings. Greater ability for the adjustment of temperatures ranges as per the end user's requirement.
- ✓ **100% Tested.** All unit condensing are tested 100%, in helium chambers to refrigerant leak detections.
- ✓ **Certified.** Audited and Certified by **INTERTEK** for compliance with UL 471 and NSF 7. AENOR audited and certified by internationally recognized firm. ISO 9001:2008 (Quality); ISO 14001:2004 (Environmental); OSHAS 18001:2007 (Prevention and Worker Safety)
- ✓ **Lighting.** LED lighting in the canopy and cabinet sides reduces the energy consumption by 80% and 90% compared to a traditional bulb. Provides a much better light quality.

MODELS	Dimensions (inches) (mm)			Lateral Thickness (inches) (mm)	Surface Exposure (ft ²) (m ²)	Ref.	Ref. Weight (Lbs.) (gr.)	Temp. Range (°F) (°C)	Cond. Unit. H.P.	Case Amps 115 V.	Crated Weight (Lbs.)(Kg.)
	W	D	H								
IDC-VML12	49-1/4	35-1/2	48-5/8	1-1/8+1-1/8	8.5	R134a	0.79	30°F/34°F	1/3	5.0	342
	1250	900	1235	40+40	0.79		360	-1°C/+1°C			155
IDC-VML15	61-1/2	35-1/2	48-5/8	1-1/8+1-1/8	10.65	R134a	1.21	30°F/34°F	1/2	7.78	401
	1562	900	1235	40+40	0.99		550	-1°C/+1°C			182
IDC-VML18	73-7/8	35-1/2	48-5/8	1-1/8+1-1/8	12.81	R134a	1.43	30°F/34°F	7/8	9.51	430
	1875	900	1235	40+40	1.19		650	-1°C/+1°C			195

ETL LISTED TO UL471 STANDARD AND SANITATION CLASSIFIED TO NSF7 – WE RESERVE THE RIGHT TO CHANGE SPECIFICATIONS WITHOUT PRIOR NOTICE



Infrico USA Corp.
 7042 N.W. 46th Street
 Miami, FL 33166
 1.305.777.9599 Office
 1.305.777.9598 Fax

www.infrico.us
 operations@infrico.com
 service@infrico.com
 sales@infrico.com

APPROVALS: AVAILABLE AT:



Revision: 01 Date: 20/01/2015 VML12, VML15, VML18_FT_02_1



Project: _____

Location: _____

Item #: _____ Quantity: _____

Model #: _____

MODELS: IDC-VML12 IDC-VML15 IDC-VML18 Fish displays case Malaga series

STANDARD FEATURES

➤ Exterior

- AISI 304 Stainless Steel,
- AISI 304 Stainless Steel worktop,
- Sliding door back,
- Curved tempered security glass system.

➤ Interior

- AISI 304 Stainless Steel,
- Base of enamelled steel tube,
- Internal drain for easy cleaning,
- LED lighting.



➤ Insulation

- CFC-Free polyurethane insulation, entire cabinet structure is foamed-in place using a high density polyurethane insulation,
- Low GWP & Zero ODP effect.

➤ Casters

- 4" diameter casters,
- Locks provided on back set.

➤ Refrigeration

- Temperature regulated by a digital controller,
- Manual defrost,
- System of Ventilated condensation
- System of Static+Board Evaporation,
- Evaporator coil coated with anti-corrosion material,
- Climate class 4 (86°F (30°C), 55% HR).

➤ Electrical

- Cord and NEMA 5-15P plug,
- Electrical connection is 115V / 1ph / 60 Hz.



➤ ETL Listed to UL471 Standard and Sanitation classified to NSF7.

OPTIONAL FEATURES

- ✓ Frontal LED lighting,
- ✓ Electrical connection is 220V / 1ph / 50 Hz.

PLAN VIEW

ELEVATION VML12

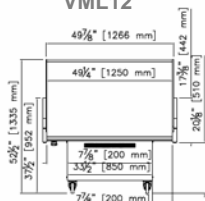

VML15

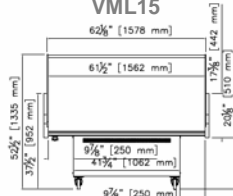

VML18

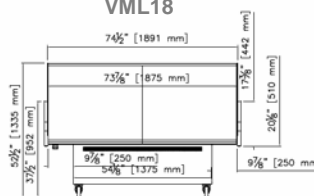

RIGHT VIEW

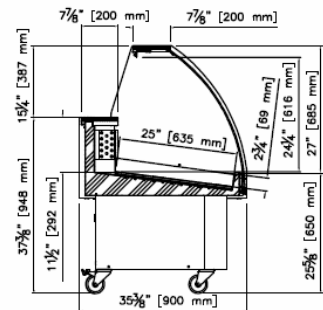

PLAN VIEW

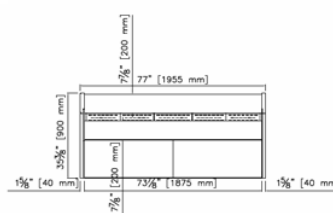
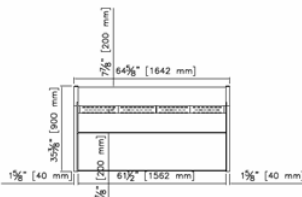
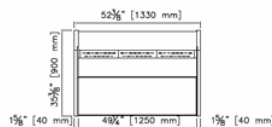

ETL LISTED TO UL471 STANDARD AND SANITATION CLASSIFIED TO NSF7 – WE RESERVE THE RIGHT TO CHANGE SPECIFICATIONS WITHOUT PRIOR NOTICE



Infrico USA Corp.
7042 N.W. 46th Street
Miami, FL 33166
1.305.777.9599 Office
1.305.777.9598 Fax

www.infrico.us
operations@infrico.com
service@infrico.com
sales@infrico.com

APPROVALS: AVAILABLE AT: