



CE ISO 9001

## D25 CHILLED BEVERAGE MACHINE

The D25 is a high volume chilled beverage machine designed for reliability and ease of use in an attractive mirror stainless finish that accents any placement. The D25 offers an energy efficient cooling system for low cost operation.

### Features

- Cooling plate on the bottom of the bowl allows beverage cooling down to the last drink.
- Simple two-piece stainless steel dispensing valves are easy to clean and maintain.
- Attractive all stainless steel exterior provides easy cleaning and reduced maintenance.
- Detachable oversized 4.75 gallon (18 L) durable polycarbonate bowls for easy cleaning and lasting durability.
- Engineered evaporator provides fast and efficient cooling with reduced power usage.
- Mixers and bubbler pumps are standard features that are perfect for lemonades, fresh juices, coffees, or teas.

**DONPER** USA

Donper USA  
24610 Kingsland Blvd  
Katy, TX 77494

1-844-366-7371  
sales@donperusa.com  
www.donperusa.com

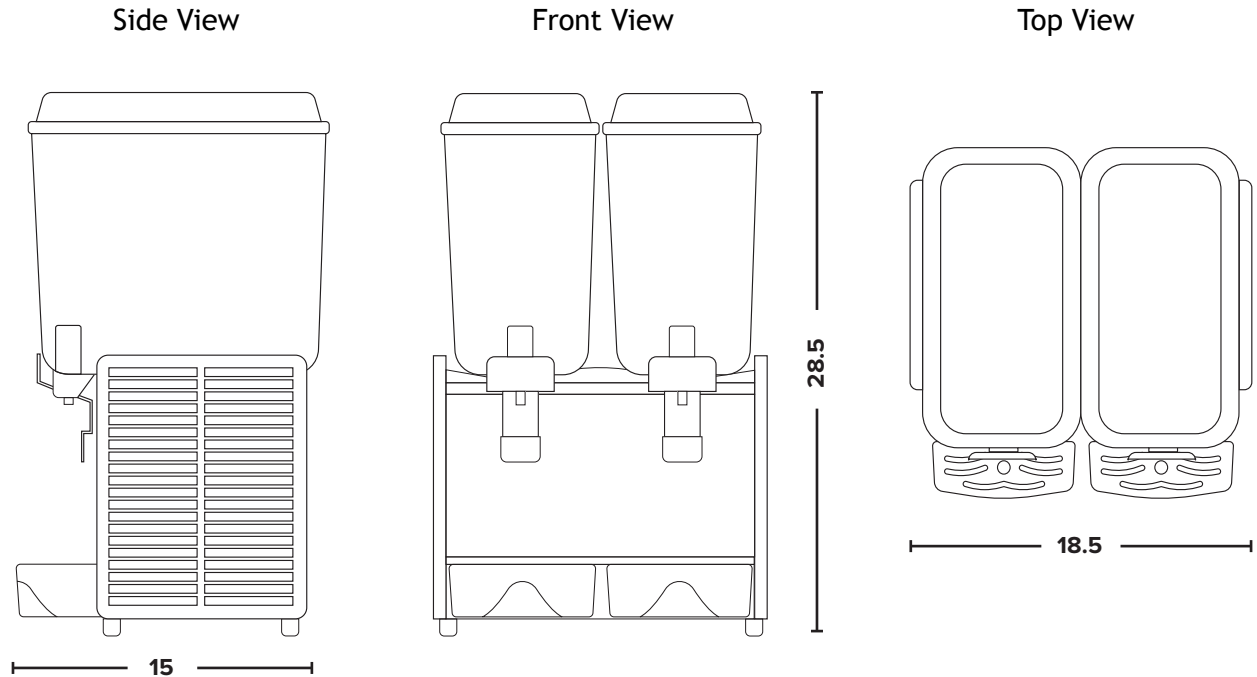

Measurements in inches.

## Size and Capacity

Bowl (each)	4.75 Gal (18 L)
Height	28.5 in (724 mm)
Width	18.5 in (470 mm)
Depth	15 in (381 mm)
Weight	70.5 lbs (32 kg)

## Electrical

Voltage	115 v
Phase	Single
Rated Input Power	8.5 A
Hertz	60 Hz
Plug Type	115 volt Standard Plug

## Distributed By:

---