

# REACH-IN FREEZER (0°F)

## Model: 1FXNPT

Natural Refrigerant R-290 Model

### 1-Section Extra-Wide Pass-Thru Freezer

**1FXNPT** - Stainless steel front, aluminum end panels and interior  
**1FXNSAPT** - Stainless steel exterior, aluminum interior  
**1FXNSSPT** - Stainless steel exterior and interior  
**Designed to maintain NSF-7 temperatures in 100°F ambient.**



## Options and Accessories

(upcharge and lead times may apply)

Additional epoxy coated steel shelves	Hinged glass door (consult factory)
Chrome or stainless steel shelves	Special electrical req. (consult factory)
Rehinging of doors (consult factory)	<b>Correctional Facility Options</b>
Half doors	<ul style="list-style-type: none"><li>One way security screws</li></ul>
Adjustable legs	<ul style="list-style-type: none"><li>Locking hasp (lock not included)</li></ul>
Custom laminates	<ul style="list-style-type: none"><li>Stainless steel mesh cover</li><li>Coverless hinges</li></ul>

Consult factory for other model configurations, options and accessories.

**Continental**<sup>®</sup>  
Refrigerator

Toll-Free: 800-523-7138  
Phone: 215-244-1400  
Fax: 215-244-9579

539 Dunksferry Road  
Bensalem, PA 19020  
[www.continentalrefrigerator.com](http://www.continentalrefrigerator.com)

Project Name:

Model Specified:

Location:

Item No:

Quantity:

AIA #:

SIS #:

## Standard Model Features

### REFRIGERATION SYSTEM

Natural, environmentally safe,  
high efficiency R-290 refrigerant<sup>1</sup>

Self contained, performance rated refrigeration system

Automatic, electric condensate evaporator

### CABINET ARCHITECTURE

3" non-CFC polyurethane foam insulation

Smooth, polished chrome workflow door handles

Cam action, lift off hinges

Self-closing doors

Magnetic snap in Santoprene™ door gaskets

Cylinder lock in door

Heavy duty, epoxy coated steel shelves

5" casters

### MODEL FEATURES

LED interior lighting

Expansion valve system

Digital thermometer

Automatic electric defrost

<sup>1</sup> R-290 refrigerant meets all federal and state regulatory requirements.

APPROVAL:

# Model Specifications

## DIMENSIONAL DATA

Net Capacity (cubic feet)	30 (850 cu l)
Width, Overall (inches)	36 1/4 (921 mm)
Depth, Overall (inches) (including handles)	38 3/4 (984 mm)
Depth [less doors] (inches)	32 (813 mm)
Depth [doors open 90°] (inches)	100 (2540 mm)
Clear Door Width (inches)	29 5/8 (752 mm)
Clear Door Height (inches)	58 5/8 (1489 mm)
Height, Overall (inches) (including 5" casters)	82 1/4 (2089 mm)
Number of Doors	2
Number of Shelves	3
Shelf Area (square feet)	24.4 (2.3 sq m)

## REFRIGERANT DATA

Condensing Unit Size (H.P.)	1
Capacity (BTU per hour)*	1840

## ELECTRICAL DATA

Voltage (International)	115/60/1 (220/50/1)
Feed Wires (including ground)	3
Total Amps (International)	8.4 (4.9)
Defrost Amps	5.2 (2.6)
10 ft. Cord/Plug [attached] (International)	Yes (No)

## SHIPPING DATA

Height - Crated (inches)	85 1/2 (2172 mm)
Width - Crated (inches)	42 (1067 mm)
Depth - Crated (inches)	42 (1067 mm)
Volume - Crated (cubic feet)	87 (2464 cu l)
Weight Std - Crated (pounds)	450 (204 kg)
Weight SS - Crated (pounds)	510 (231 kg)
Weight Std - Uncrated (pounds)	350 (159 kg)
Weight SS - Uncrated (pounds)	410 (186 kg)

\* Rating @ -15°F evaporator, 90°F ambient  
Figures in parentheses reflect metric equivalents rounded to the nearest whole unit.



Equipped with one NEMA-5-15P Plug  
(varies by country)

# Model Plan Views

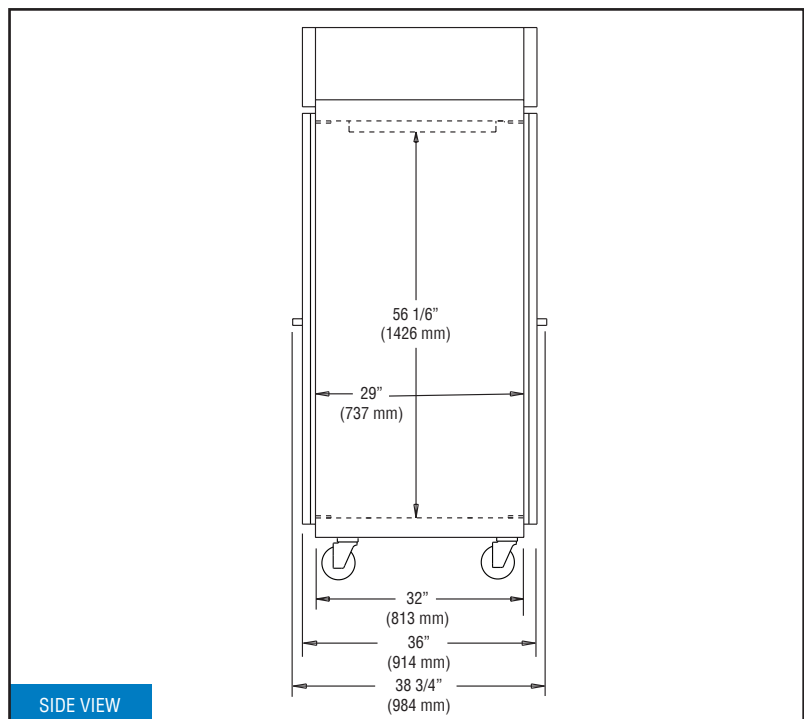
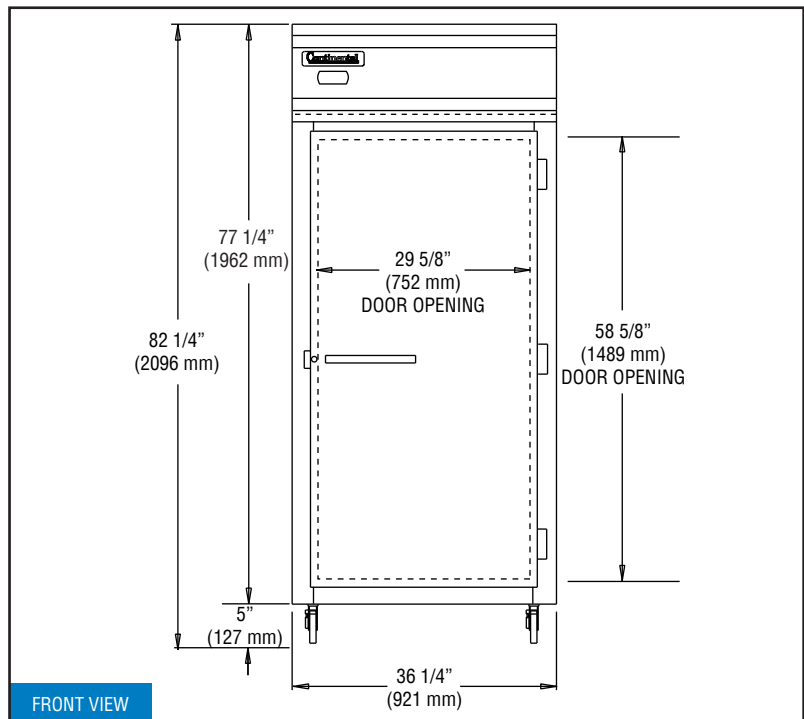

**IMPORTANT NOTE:** If the cabinet is located under a low ceiling, a minimum clearance of 12" is required on top and 3" on sides.

**Continental**  
Refrigerator

Toll-Free: 800-523-7138  
Phone: 215-244-1400  
Fax: 215-244-9579

539 Dunksferry Road  
Bensalem, PA 19020  
[www.continentalrefrigerator.com](http://www.continentalrefrigerator.com)

Due to our continued efforts in developing innovative products, specifications subject to change without notice.

