

DOUGHPRO™



Simply The Best Dough Press Around

PP2018 Economy Manual Dual Heated Dough Press



If pizza is not your main menu item then this press is designed for you. The ProLuxe PP2018 is simple to use, and super easy to clean. It can create crust equal to hand tossed perfectly every time. Most importantly, this product's ease of use allows anyone to master the art of dough forming. Based on patented technology, the embedded heating element guarantees long-lasting performance.

Features

- Digital control with timer and counter.
- Heated upper and lower platen helps cold dough flow faster.
- Manually operated, no motor or compressors required.
- Flattens all size pizzas up to and including 18" (46 cm) diameter.
- Patented technology
- Heating element is backed by the exclusive ProLuxe limited lifetime warranty.
- Patented base suction prevents press from moving or falling.

In addition to the quality execution and unique customization capabilities, our expert technical support team supports the ProLuxe PP2018. We are available 24 hours a day/7 days a week to answer any questions and provide you with great, no-debate service support.

PROLUXE ™

formerly DoughPro. New Name. Same Quality. Superior Service.

proluxe.com



DOUGHPRO™

Simply The Best Dough Press Around

PP2018 Economy Manual Dual Heated Dough Press

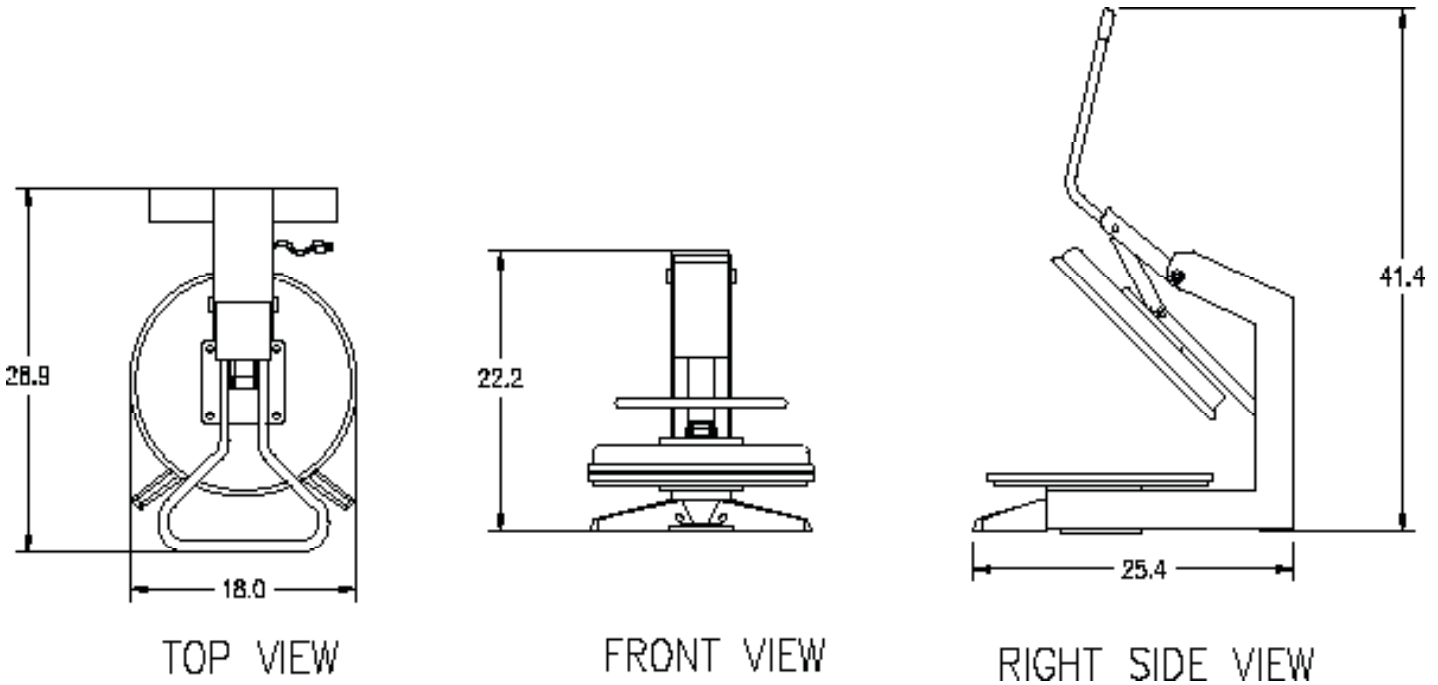

Care and Cleaning-

The use of a mild soapy water solution and a soft sponge to clean the upper and lower platens.

ON/OFF Switch	Yes	Electrical Data PP2018B - 240v/50/60hz 3000w/12.5 amps - NEMA 6-15P
Programmable Timer	Yes	
Temperature Control	Yes	
Thickness Adjustment	No	Shipping Weight 137lbs/62kg Machine Weight 103lbs/46kg
Maximum Heat	0-450 F	

Power cord length 72"

Listed:



Intertek



Intertek



20281 Harvill Ave | Perris, CA 92570

t: (951) 657-0379 | t: (800) 624-6717 | f: (951) 657-4594

w: www.proluxe.com | e: info@prolux.com