

# Rotisol



 BASKET RÔTISSERIE

## Rôti-Roaster FBP8.520

### DESIGN

- High performance, elegant and modern rotisserie with interior lighting to accentuate your roasting meats and vegetables
- All stainless steel body
- Optional: Double-convex, anti-burn glazing with illuminated "ROTISSERIE" sign

### CULINARY ADVANTAGES

- Rapid roasting while still retaining rotisserie quality
- Display and programming of cooking time and temperature
- 6 cooking programs with alert at end of cycle - products can then be maintained at 145° F
- Latest range of heating elements
- 5 chicken baskets engineered for easy unloading
- Also suitable for other poultry, meats and vegetables

### SAFETY

- K.Glass door reduces heat loss, hence quicker cooking times, and prevents burns
- Automatic cooling of the heating turbine at the end of the cooking cycle
- Drip pan with plug to collect grease for ensured hygiene and safety
- New generation of rotisserie with very low energy consumption, fully insulated model



Optional double convex, anti-burn glazing



### CLEANING

- Disassembly of all cooking accessories for simple cleaning
- Removable inside panel and grease pan for easy cleaning
- Protection of the interior lighting by ceramic glass for easy surface cleaning

### ACCESSORIES



Front view

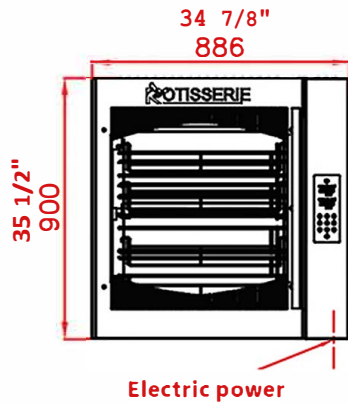

Side view

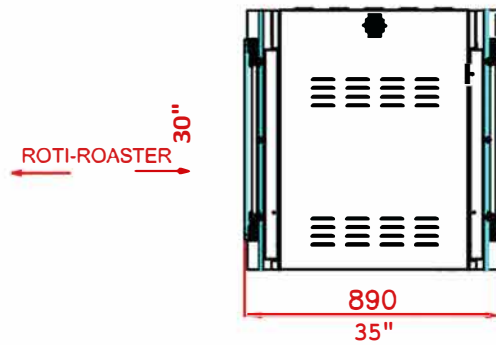

Top view

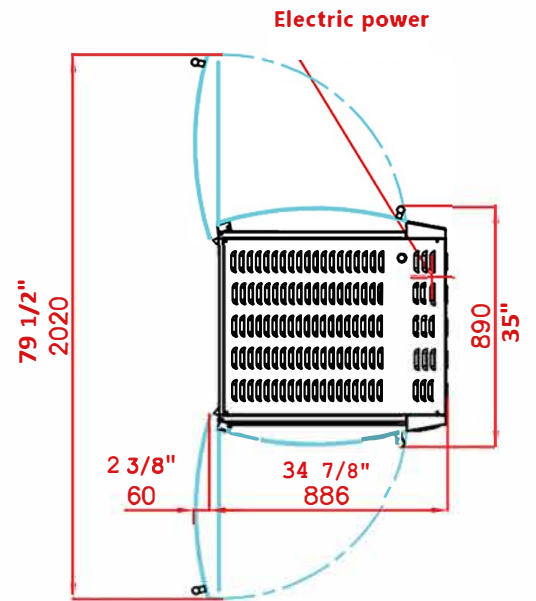

34 1/8"  
868

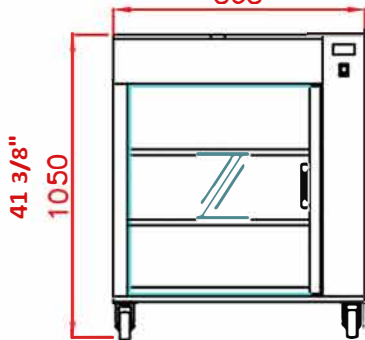

31 1/8"  
790

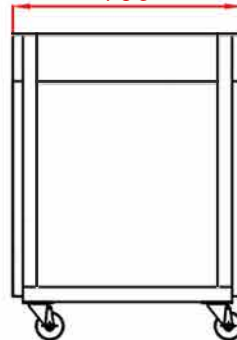

34 1/8"  
868

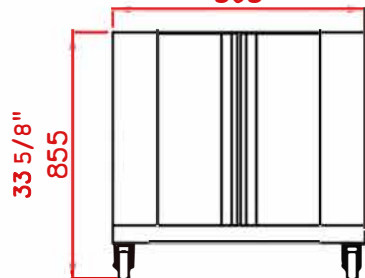

27 5/8"  
700

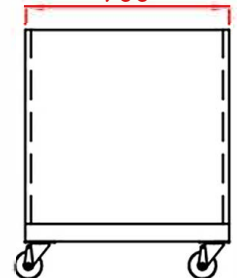

Shown with optional Band with illuminated sign

## STANDARD FIXTURES

- Standard Finish - Stainless Steel
- 8 Chicken Baskets
- 2 tempered glass doors (K.Glass)
- Drip pan
- Removable protective inside side panels

## SPECIFICATIONS

Electricity

6.4 KW / 3-phase / 208-240v / 60 Hz

Capacity

24-32 CHICKENS

Warranty

1 year

Venting

A hood must be installed to conform to all local codes

Minimum clearance

2 1/2" at the right, left and rear

