



Your Solutions Partner

Specifications

F.O.B. Sedalia, Missouri 65301



ADI-3MSL

OPTIONS:

- Condensate Evaporator
- Hot food style top
- Stainless steel louvered grille
- False Bottom
- Designer Foodshields
- Stainless steel adapter panels
- Adapter bars

AGENCY LISTING:



DUKE MANUFACTURING CO.

2305 N. Broadway
 St. Louis, MO 63102
 800.735.3853 Toll Free
 314.231.5074 Fax
 www.dukemfg.com

Approval Stamp(s):

PRODUCT INFORMATION:

PROJECT: _____
 ITEM: _____
 QUANTITY: _____

MODEL:

**Drop-Ins - Slimline - Cold Pan
 Mechanically Assisted Ice Pan - 5" Deep Liner**

- ADI-2MSL** Holds two (2) 4" Deep 12" x 20" pan
- ADI-3MSL** Holds three (3) 4" Deep 12" x 20" pan

TOP RIM:

- Heavy gauge, 300 Series stainless steel
- Overhang on all four sides w/locking tabs
- Reinforced with heavy gauge steel angle
- Vinyl foam gasket as sealant

LINER:

- 300 Series stainless steel cold pan
- 5" deep 11-7/8" front to back
- 1" cast brass drain and plug
- Adapter bars for full size pans included

REFRIGERATION:

- Copper coils attached to bottom of liner
- R448A refrigerant
- Air cooled condensing unit, in center of unit
- Open angle-iron suspended compressor compartment
- Remote mounted on/off switch with stainless steel face plate
- 120V condensing unit
- 6' cord and plug - NEMA 5-15
- Five year warranty on compressor motor

EXTERIOR HOUSING

- Heavy gauge paint grip steel

Specification subject to change



Drop-Ins - Slimline - Cold Pan Mechanically Assisted Ice Pans 5" Deep Liner

A.I.A. File No. 35-C-13

Catalog No. SLIMMECHS

DROP-IN - SLIMLINE - COLD PAN - MECHANICALLY ASSISTED - 5" DEEP LINER

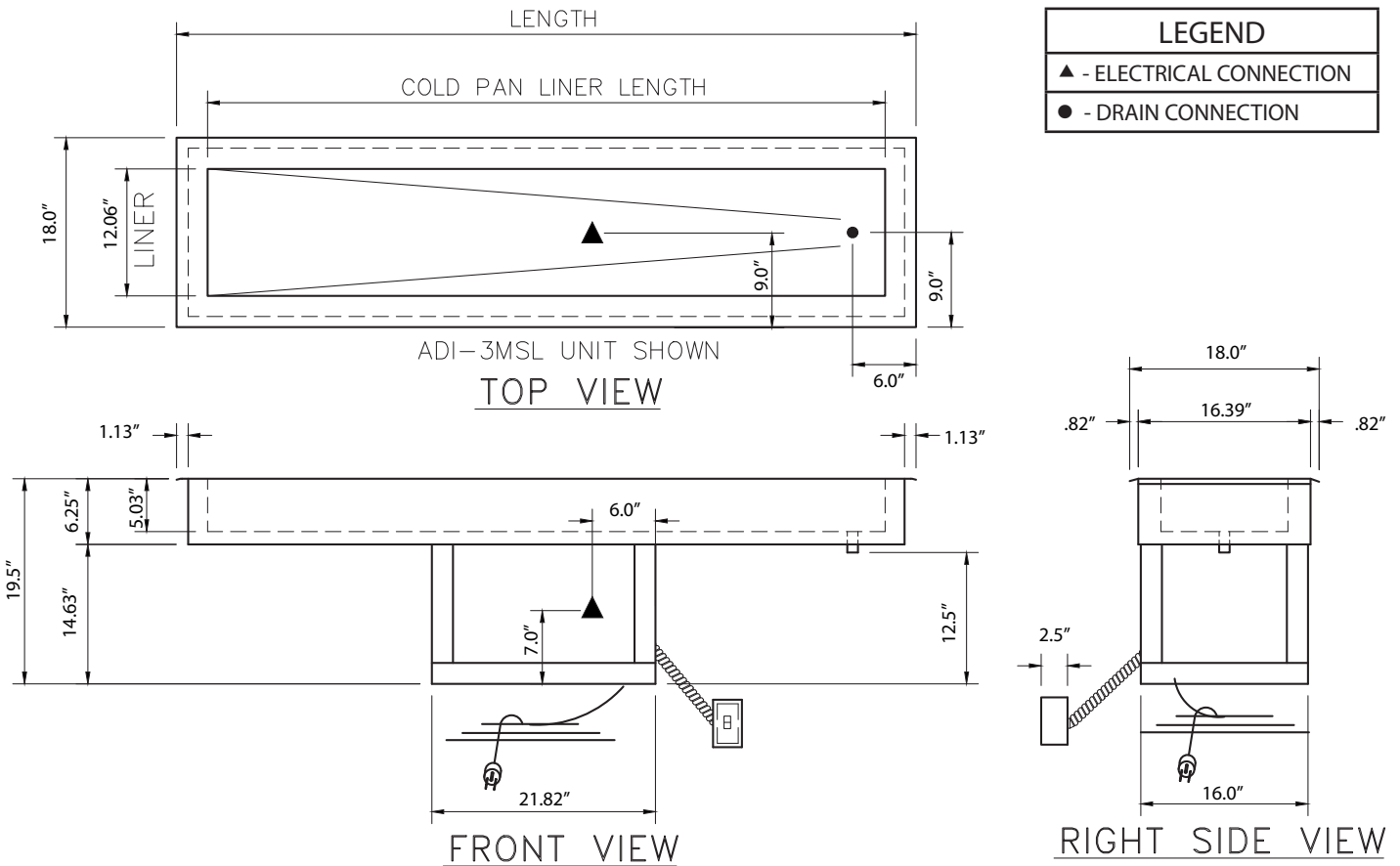

ELECTRICAL SPECIFICATIONS

Model	120 Volt	
	Amps	HP
ADI-2MSL	4.26	1/4
ADI-3MSL	4.26	1/4

DIMENSIONS - Liners are 11-7/8" (30.3 cm) W; cutouts 16-3/4" (42.3cm) W

FREIGHT CLASS: 100

Model	Length		Width		Height		Cube ft crated	Weight		Cold Pan - L		Cutout - L	
	in.	cm	in	cm	in	cm		lbs	kg	in	cm	in	cm
ADI-2MSL	48 ¼	122.6	18	45.7	19 ½	46.4	18.1	155	70.5	42 ¼	107.3	47	121.9
ADI-3MSL	70 ¼	178.4	18	45.7	19 ½	46.4	25.5	205	93.2	64 ¼	163.2	69	178.0

REMOTE CONTROL CUTOUT IS 4-1/8" H X 2-3/16" W



Duke Manufacturing Co.
2305 N. Broadway
St. Louis, MO 63102

Phone: 314-231-1130
Toll Free: 1-800-735-3853
Fax: 314-231-5074

www.dukemfg.com

Printed in U.S.A
© 2020, Duke Manufacturing Co.