

Belshaw's **HI-series Donut Icers** provide fast, uniform icing of cake and yeast-raised donuts, with a minimum use of hands to touch the product or icing.

- Full screens (or baking pans) can be easily iced in one minute or less with consistent, uniform coverage. Easy changeover to different flavors is accomplished by using extra Icing Pans.
- **HI18F** ices 24 donuts at a time, on 17" x 25" glazing screens or 18" x 26" baking pans. The capacity of the HI18F is approximately 120 dozen donuts per hour.
- **HI24F** ices up to 36 donuts at a time, on 24" x 24" glazing screens. The capacity of the HI24F is approximately 180 dozen donuts per hour.
- The HI18 and HI24's unique donut handling system submerges one side of the donuts into warm icing, held in a large capacity Icing Pan and warmed from below by a uniform radiant Heating Panel. The finished product is uniformly iced with a minimum of drips.
- For high capacity production, several icers may be used simultaneously. The large, easy to use submerging handle can be placed on either side, enabling one person to conveniently operate two icers at a time. An extra lift handle is optional to enable operation from both sides as needed.
- Belshaw's HI18 and HI24 Icers have been upgraded for quality and convenient operation. Heavy-duty construction and sound design facilitate cleaning and provide a durable product.

Electronic temperature controller

- HI18F and HI24F both feature an electronic temperature controller to manage icing temperature. The controller operates as a highly accurate thermostat, and allows the operator to monitor temperature on an LCD display.

ACCESSORIES

- **Drip Tray.** When the icer is in use, the optional Drip Tray is swung into position so it is under the donuts just after they are coated with icing.
- **Extra Icing Pans.** The Icing Pan holds the icing in the icer. One Icing Pan is supplied with every Icer. If 3 icing flavors are used, 2 extra Icing Pans may be ordered and the pans can be quickly inserted whenever needed.
- **Extra Heating Panels.** Used to warm an Icing Pan containing donut icing (as described above). An extra Heating Panel can be used to warm whichever icing flavor is to be used next.
- **Screens for holding donuts**
 - 17" x 25" Part # SL200-0004 Holds 24.
 - 24" x 24" Part # HG24-0001 Holds 25-36, dependent on donut size.
 - Baking pans may be used instead of screens. A simple adapter is supplied for changeover.
- **Extra Lift Handle.** Enables operation from both sides as needed.



HI18F (with donut tray closed)



HI24F (with donut tray open)

HI18F with donut tray open



Electronic Temperature Controller

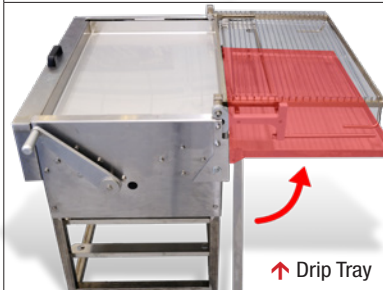

Drip Tray



Heating Panel

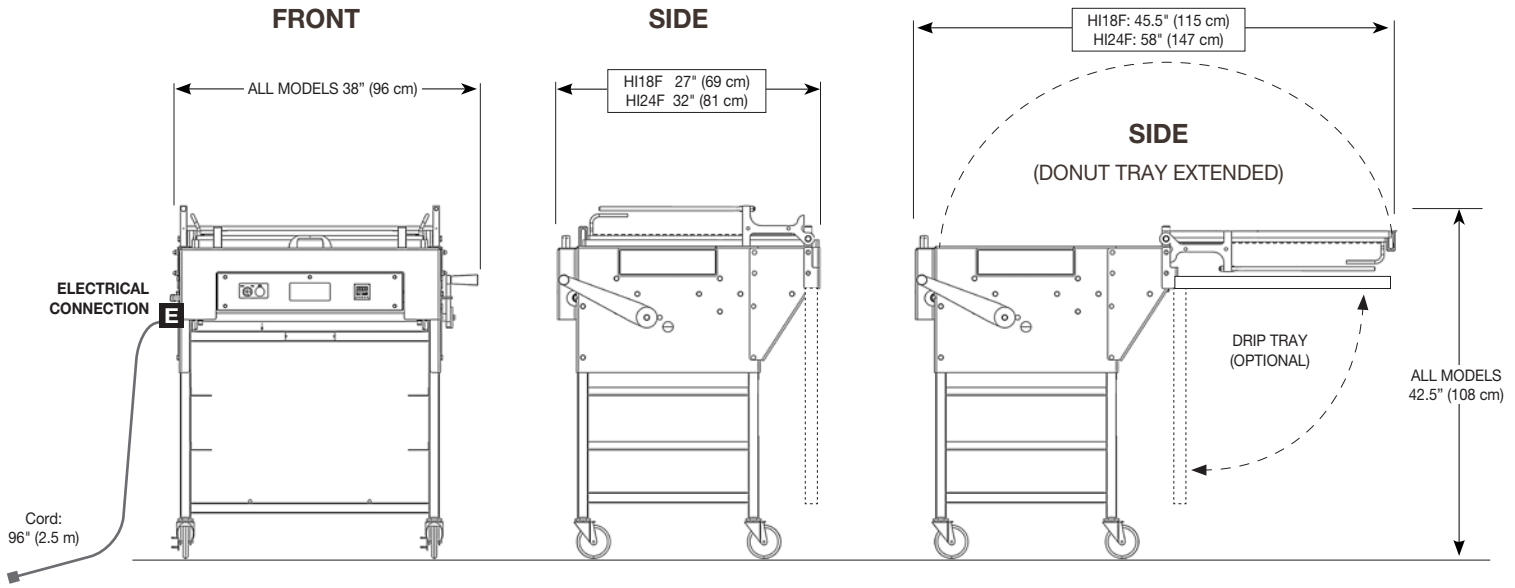

STANDARD FEATURES

- Heavy duty stainless steel and aluminum construction.
- Electronic heat controller, maximum temperature 130° F (54.5° C).
- Actual icing temperature always available from probe, attached to icing pan, or handheld.
- High temperature limit switch.
- Sturdy front cover to prevent damage to front side controls.
- Large, easy to use operating handle for submerging donuts. Supplied on right side of icer, field reversible to left side.
- Stainless steel cover for Icing Pan.
- Removable components for easy cleaning.
- 3 storage shelves for additional Icing Pans, Heating Panels, Screens or Pans.
- 4 casters, 2 lockable.
- 120V or 208-240V models available.

CERTIFICATIONS

- Certified to UL-197, CSA 22.2, and NSF-4.
- CE models available.

ACCESSORIES

	HI18F	HI24F
Glazing Screens	SL200-0004	HG24-0001
Icing Pans	HI18-0001	HI24-0006
Heating Panel (120V)	HI18-1300	HI24-1300
Heating Panel (240V)	HI18-1300-240	HI24-1300-240
Heating Panel (240V) CE/European Union models	HI18-1300-240CE	HI24-1300-240CE
Drip Tray	HI18-1510	HI24-1510
Extra Lift Handle (kit)	HI18-1507	

SPECIFICATIONS

		HI18F	HI24F
COMPATIBLE GLAZING SCREENS	inches	17" x 25"	24" x 24"
	part number	SL200-0004	HG24-0001
BAKING PAN SIZE	inches	18" x 26"	24" x 24"
ICING PAN CAPACITY (Approximate)	lbs	50 lbs	60 lbs
	kg	22.7 kg	27.3 kg
	gallons	7 gal	8.3 gal
	liters	26 L	31.3 L
ELECTRICAL DATA			
120V, 60hz, 1ph	amps	7.5 A	10 A
	kilowatts	0.9 KW	1.2 KW
208-240V, 50/60hz, 1ph	amps	2.5 – 3.1 A	4.3 – 5 A
	kilowatts	0.5 – 0.7 KW	0.9 – 1.2 KW
Extra heating panels require their own connection.			
PLUG	120V	NEMA 5-15P	
	240V N.America	NEMA 6-15P	
	240V International	CEE 7/7	
CORD	length	96 inches (2.5 m)	
SHIPPING DIMENSIONS (Approximate, shipped in carton on pallet or crate)	inches	48" x 42" x 54"	48" x 42" x 54"
	cm	122x107x137 cm	122x107x137 cm
	lbs	250 lbs	300 lbs
	kg	114 kg	136 kg
FREIGHT CLASS		100	100