



# MODEL DFG-200-ES Full-Size Convection Oven



Project \_\_\_\_\_

Item No. \_\_\_\_\_

Quantity \_\_\_\_\_

Extra depth baking compartment - accepts five 18" x 26" standard full-size baking pans in left-to-right or front-to-back positions.

All data is shown per oven section, unless otherwise indicated.

Refer to operator manual specification chart for listed model names.

DFG-200-ES

### EXTERIOR CONSTRUCTION

- Stainless steel front, top, and sides
- Dual pane thermal glass windows encased in stainless steel door frames
- Powder-coated door handle with simultaneous door operation
- Triple-mounted pressure lock door design with turnbuckle assembly
- Ball bearing slide out front control panel for easy servicing
- 1" solid block plus 1" mineral fiber insulation for a total of 2" of insulation

### INTERIOR CONSTRUCTION

- Full angle-iron frame
- Double-sided porcelainized baking compartment liner (16 gauge)
- Stainless steel combustion chamber
- Single inlet blower wheel
- Five chrome-plated racks, eleven rack positions with a minimum of 1-5/8" (41mm) spacing
- Interior halogen lights

### OPERATION

- Direct fired gas system
- Electronic spark ignition control system
- Removable inshot burners
- Internal pressure regulator
- Manual gas service cut-off switch located on the front of the control panel
- Solid state thermostat with temperature control range of 200°F (93°C) to 500°F (260°C)
- Two speed fan motor
- 3/4 horsepower blower motor with automatic thermal overload protection
- Control area cooling fan

### STANDARD FEATURES

- SSD - Solid state digital control with LED display, Cook & Hold and Pulse Plus®
- 25" (635mm) adjustable stainless steel legs (for single units)
- 6" (152mm) adjustable stainless steel legs (for double sections)
- Three year parts and two year labor warranty
- Five year limited oven door warranty\*

\* For all international markets, contact your local distributor.



### OPTIONS AND ACCESSORIES

(AT ADDITIONAL CHARGE)

- **Legs/casters/stands:**
  - 6" (152mm) seismic legs
  - 6" (152mm) casters
  - 4" (102mm) low profile casters (double only)
  - 25" (635mm) stainless steel stand w/rack guides
  - 29" (737mm) stainless steel, fully welded open stand with pan supports
- **Controls:**
  - SSI-D - Solid state infinite control w/digital timer
  - SSI-M - Solid state infinite control w/manual timer
  - SimpleTouch - NEW touchscreen control with ability to store and group recipes. Includes rack timing, Cook&Hold, Fan Delay, Fan Pulse, easy download for recipe writing on your laptop, and HAACP storage capability
- **Gas hose w/quick disconnect restraining device:**
  - 48" (1219mm) hose
  - 36" (914mm) hose
- Stainless steel oven liner
- Extra oven racks
- Stainless steel solid back panel
- Gas manifold (for double sections)
- Prison package (includes security control panel and stainless steel back)
- Flue connector
- Direct vent

### OPTIONS AND ACCESSORIES

(AT NO CHARGE)

- Solid stainless steel doors

### BLODGETT OVEN COMPANY

[www.blodgett.com](http://www.blodgett.com)

42 Allen Martin Drive, Essex Junction, VT 05452

Phone: (802) 658-6600 • Fax: (802) 864-0183



# DFG-200-ES

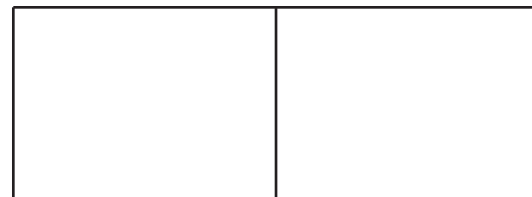

APPROVAL/STAMP

DIMENSIONS ARE IN INCHES (MM)

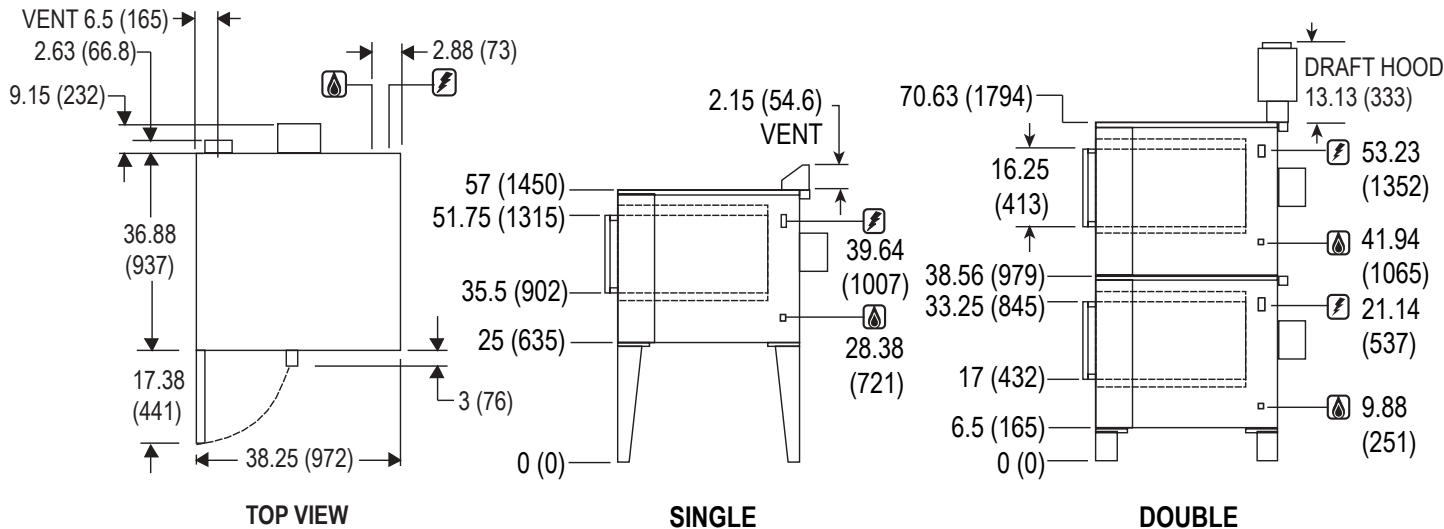

**SHORT FORM SPECIFICATIONS** - Provide Blodgett full-size, bakery depth convection oven model DFG-200-ES, (single/double) compartment. Each compartment shall have porcelainized/stainless steel liner and shall accept five 18" x 26" standard full-size bake pans in left-to-right or front-to-back positions. Stainless steel front, top and sides. Doors shall be (solid stainless steel/dual pane thermal glass windows) with single powder-coated handle and simultaneous operation. Unit shall be gas heated with electronic spark ignition and shall cook by means of a direct fired system with a gas shutoff switch on the front of the control panel. Air in baking chamber distributed by single inlet blower wheel powered by a two-speed, 3/4 HP motor with thermal overload protection. Each chamber shall be fitted with two halogen lamps, five chrome-plated removable racks and removeable crumb trays. Control panel shall be recessed with solid state digital control with LED display, Cook & Hold and Pulse Plus. Provide three years parts, two year labor and five year door warranty. Provide options and accessories as indicated.

**DIMENSIONS:**

Floor space 38-1/4" (972mm) W x 36-7/8" (937mm) D  
 Product clearance 0" from combustible and non-combustible construction  
 Interior 29" (737mm) W x 20" (508mm) H x 28-1/4" (718mm) D

**If oven is on casters:**

Single Add 4-1/2" (114mm) to all height dimensions  
 Double Height dimensions remain the same  
 Double Low Profile Subtract 2.5" (64mm) from all height dimensions

**GAS SUPPLY:**

3/4" NPT  
 Manifold Pressure:  
 • Natural – 3.5" W.C      • Propane – 10" W.C.  
 Inlet Pressure:  
 • Natural – 7.0" W.C. min. – 10.5" W.C. max.  
 • Propane – 11.0" W.C. min. – 13.0" W.C. max.

**MAXIMUM INPUT:**

Single 50,000 BTU/hr (14.6 Kw)  
 Double 100,000 BTU/hr (29.2 Kw)

**POWER SUPPLY:**

115 VAC, 1 phase, 8 Amp, 60 Hz., 2-wire with ground,  
 3/4 H.P., 2 speed motor, 1120 and 1680 RPM  
 6' (1.8m) electric cord set furnished on 115 VAC ovens only  
 230V CE model, 1 phase, 3 Amp, 50 Hz., 2-wire with ground,  
 1/2 H.P., 1 speed motor, 1440

Blodgett recommends a Pass & Seymour, model 2097, GFCI due to the use of a variable frequency drive. Must be hard wired in some cases.

**MINIMUM ENTRY CLEARANCE:**

Uncrated 32-1/16" (814mm)  
 Crated 37-1/2" (953mm)

**SHIPPING INFORMATION:**

**Approx. Weight:**  
 Single 590 lbs. (268 kg)  
 Double 1095 lbs. (497 kg)  
**Crate sizes:**  
 37-1/2" (952mm) x 43-1/2" (1105mm) x 51-3/4" (1315mm)

**NOTE:** The company reserves the right to make substitutions of components without prior notice

**BLODGETT OVEN COMPANY**

www.blodgett.com • 42 Allen Martin Drive, Essex Junction, VT 05452 • Phone: (802) 658-6600 • Fax: (802) 864-0183