

Specification

HPC7011-C9F9(TD)

Non Insulated Heater Proofer



- ◆ Designed for proofing and heating.
- ◆ Two doors design reduce the loss of heat and energy saving in cost.
- ◆ All digital display and controls.
- ◆ Machined Zinc Alloy handle.
- ◆ Adjustable thermostat for a variety of Warming temperatures.
- ◆ Holding temperature up to 185 °F.
- ◆ Water pan provides moisture for proofing.
- ◆ Humidity up to 95%(under 90 °F).
- ◆ Total pan capacity is sixteen full size pan(18"x26").
- ◆ Clear polycarbonate door for easy viewing.
- ◆ High quality 5" casters,two with safety-lock.
- ◆ Aluminum cabinet.



Note: Dimensions and Specification are subject to change without notice.



This full-size Heater Proofer cabinet can hold up to 16 18" x 26" full size pans, as well as a variety of others. Offering the ability to proof a variety of baked goods, allowing dough to rise before baking. All digital temperature controls with easy set up. Enables a variety of temperatures, including warming. Designed with enduring quality in mind.

Dimensions and Specifications

HPC7011-C9F9(TD)



Front View

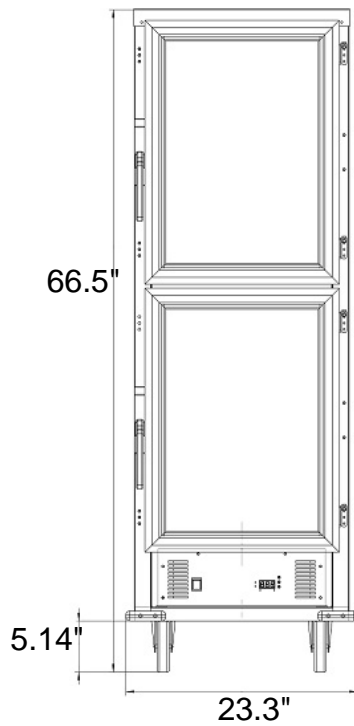

Side View

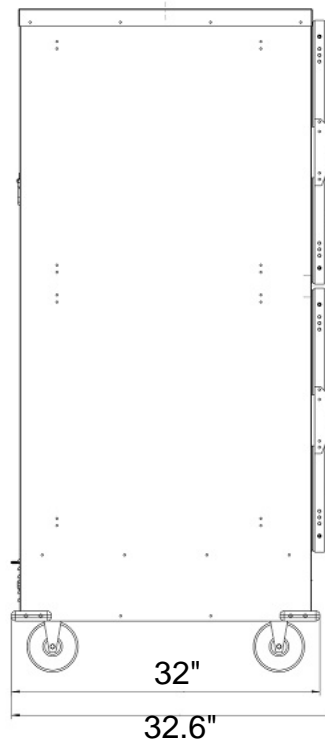

Top View

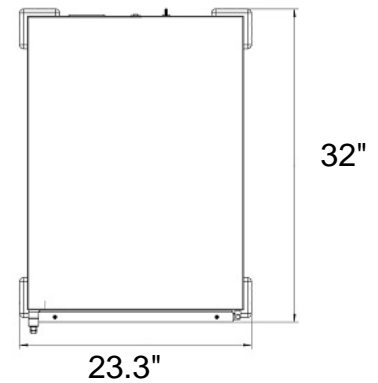

Pan Capacity 16 Story, 18" x 26" sheets

Electrical 120 Volts

Power 1500 Watts

Net Weight 138 lbs.

Gross shipping weight 156 lbs.

Class 100

Dimensions 23.3" W x 32" D x 66.6" H

Package 24" W x 33" D x 67" H

Warranty 1 Year Manufactures limited Warranty