

ITEM #: _____ QTY: _____
 MODEL #: _____
 PROJECT NAME: _____

090319

3601 S. Banker St. Effingham, IL 62401 • P.O. BOX 609 • Ph: (888) 431-2667 • Fax: (800) 433-2667

"OSC2R" DOUBLE OVERSHELVES - CANTILEVERED SERIES

16GA W/ 1.5" REAR RISER



FEATURES:

- STAINLESS STEEL SHELF WITH STALLION SAFETY EDGE ON FRONT AND 1.5" TURNUP ON REAR
- 16 GAUGE, TYPE 300 STAINLESS STEEL WITH #4 POLISH, SATIN FINISH
- UPRIGHTS ARE 1-1/2" SQUARE 14 GAUGE TUBING, TYPE 300 STAINLESS STEEL WITH #4 POLISH, SATIN FINISH
- SINGLE OVERSHELVES ARE MOUNTED 18" ABOVE TABLE TOP
- DOUBLE OVERSHELVES ARE MOUNTED 12" ABOVE FIRST SHELF
- OVERSHELVES FEATURE KNOCKDOWN SETUP
- ALL MODELS ARE APPROVED BY THE NATIONAL SANITATION FOUNDATION

CONSTRUCTION:

- STAINLESS STEEL OVERSHELVES ARE TIG WELDED
- EXPOSED WELDS ARE POLISHED TO MATCH ADJACENT SURFACES

MATERIAL:

- SHELF: 16 GAUGE, TYPE 300 STAINLESS STEEL, #4 POLISH, SATIN FINISH
- UPRIGHTS: 1-1/2" SQUARE 14 GAUGE TUBING, 14 GAUGE TYPE 300 TUBULAR STAINLESS STEEL #4 POLISH, SATIN FINISH

ACCESSORIES:

- HEAT LAMP PROVISION: OSEHLP-6XX
6=WIDTH OF PROVISION, XX=NOMINAL LENGTH OF SHELF



DOUBLE OVERSHELVES - CANTILEVERED SERIES

12" WIDTH	QTY	18" WIDTH	QTY
OSC26RK-1236		OSC26RK-1836	
OSC26RK-1248		OSC26RK-1848	
OSC26RK-1260		OSC26RK-1860	
OSC26RK-1272		OSC26RK-1872	
OSC26RK-1284		OSC26RK-1884	
OSC26RK-1296		OSC26RK-1896	
OSC26RK-12108		OSC26RK-18108	
OSC26RK-12120		OSC26RK-18120	
OSC26RK-12132		OSC26RK-18132	
OSC26RK-12144		OSC26RK-18144	

DETAILED SPECIFICATIONS

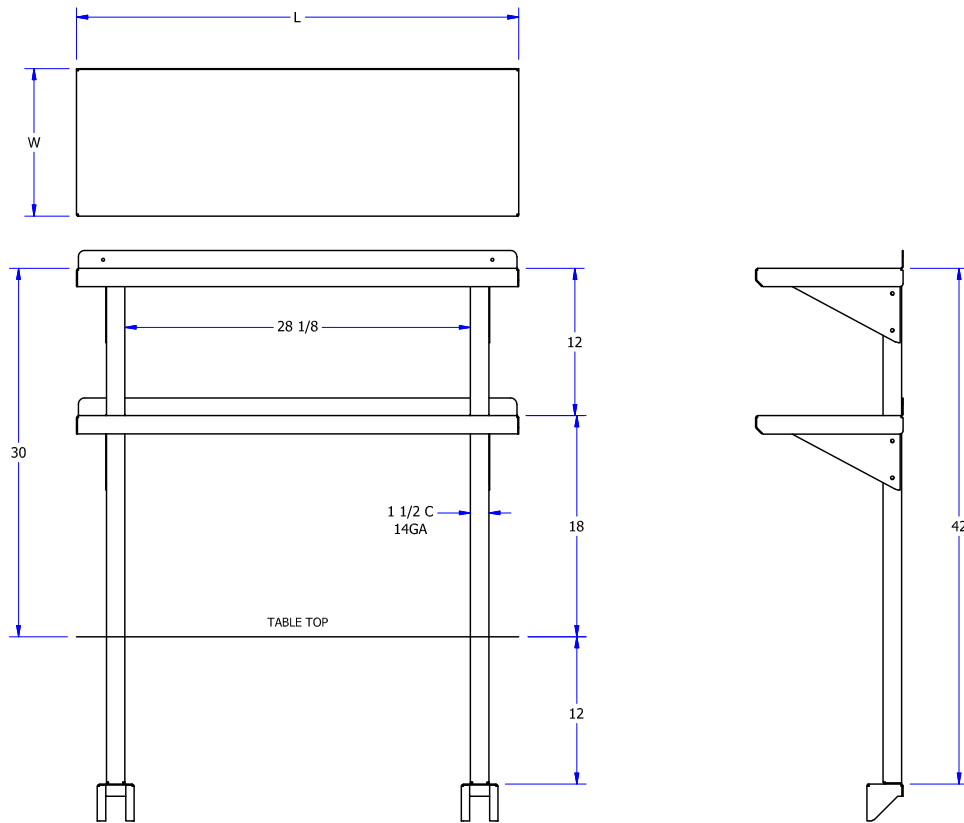

DOUBLE OVERSHELVES - CANTILEVERED SERIES

LENGTH	12" WIDTH	WEIGHT (LBS)	18" WIDTH	WEIGHT (LBS)
36"	OSC26RK-1236	48	OSC26RK-1836	52
48"	OSC26RK-1248	52	OSC26RK-1848	62
60"	OSC26RK-1260	56	OSC26RK-1860	72
72"	OSC26RK-1272	60	OSC26RK-1872	82
84"	OSC26RK-1284	70	OSC26RK-1884	100
96"	OSC26RK-1296	75	OSC26RK-1896	109
108"	OSC26RK-12108	80	OSC26RK-18108	118
120"	OSC26RK-12120	85	OSC26RK-18120	126
132"	OSC26RK-12132	92	OSC26RK-18132	135
144"	OSC26RK-12144	98	OSC26RK-18144	144

MODEL # STRUCTURE

6 = GAUGE
 2 = # OF SHELVES
 C = CANTILEVERED
 OS = OVERSHELF
 R = RISER TOP
 K = KNOCKDOWN
 12 = WIDTH (FRONT/BACK)
 36 = LENGTH (LEFT/RIGHT)

OSC26RK-1236

SOME UNITS SHIP UNASSEMBLED FOR REDUCED SHIPPING COST. ALL DIMENSIONS ARE TYPICAL. TOLERANCE +/- .500"

John Boos & Co. is constantly engaged in a program of improving products and therefore reserves the right to change specifications without prior notice.



3601 S. Banker St. • Effingham, IL 62401 • PO BOX 609 • quotes@johnboos.com

090319



www.johnboos.com

323