

Digital Cabinets 2-Door Worktop Freezer 36 " Long

ITEM # _____

MODEL # _____

NAME # _____

SIS # _____

AIA # _____



738339 (KCHUCWT36F)

2-Door Worktop Freezer 36
" Long

Short Form Specification

Item No. _____

2-door freezer counter top, with worktop, with exterior back panel, exterior bottom panel, and exterior top panel in galvanized steel, exterior side panel in 430 stainless steel; interior back, top and bottom panels in 304 stainless steel. Fin & tube condenser to improve the performances in high temperature environments. Automatic Defrost Cooling System and temperature control. Vinyl heavy duty adjustable, easy to handle and clean shelves. External temperature display.

R290 gas in refrigeration circuit.
ETL Safety and Sanitation certified.
3/5 Years warranty.

Main Features

- External temperature display.
- Removable gasket for easy cleaning operations.
- Fin & Tube Condenser improves performance in high temperature environments.
- Automatic Defrost Cooling System provides worry-free performance.
- Electronic Temperature Control, quick and simple to set, with control display for easy monitoring.
- Heavy duty Vinyl coated steel shelves.
- Cabinet completely insulated with high density polyurethane for low environmental impact.

Construction

- Stainless steel interior and exterior, durable and easy to clean for daily commercial use.
- Self-closing door with 90-degree stay-open feature.
- Heavy duty casters.
- Pre-wired heavy duty power cord.
- Heavy duty door hinges.
- Magnetic gasket removable without tools for easy cleaning.

Sustainability

- CFC and HCFC free, highly ecological refrigerant type: R290 (ecological gas in foam: cyclopentane). Hydrocarbon refrigerant gas R290 for the lowest environmental impact (GWP=3), to reduce green house and ozone depletion effects.
- High efficiency components to minimize the energy consumption still guaranteeing the highest performances.

Optional Accessories

- 1 ADJUSTABLE FOOT PNC 206445

APPROVAL: _____

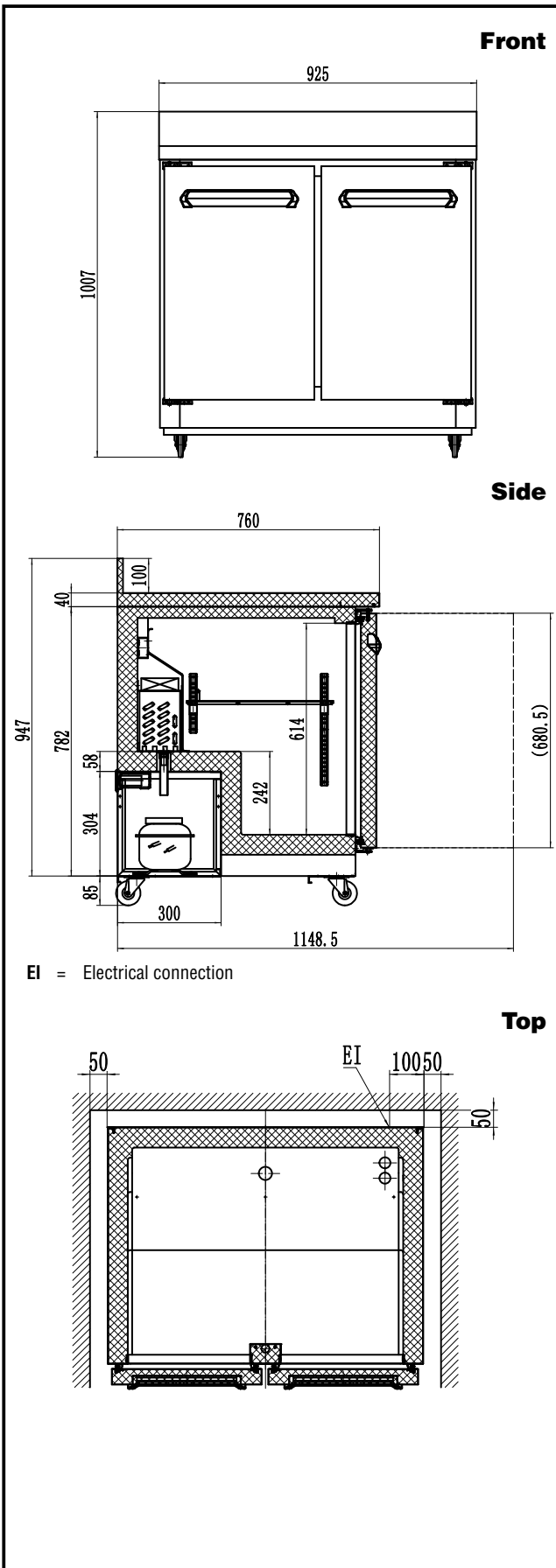

Electric

Supply voltage:	738339 (KCHUCWT36F)	115 V/1 ph/60 Hz
Electrical power, max:		0.31 kW
Plug type:		USA NEMA 5-15P

Capacity:

Gross capacity:	8.9 cu.feet
-----------------	-------------

Key Information:

Door hinges:	1 Left+1 Right
External dimensions, Width:	36 7/16" (925 mm)
External dimensions, Depth:	29 15/16" (760 mm)
External dimensions, Height:	39 7/16" (1002 mm)
Number and type of doors:	2 Full
Internal Dimensions (depth):	22 13/16"
Internal Dimensions (height):	23 1/2"
Internal Dimensions (width):	35 1/16"
Shipping height:	42 1/8" (1070 mm)
Shipping weight:	212 lbs (96 kg)
Shipping volume:	29.17 ft ³ (0.83 m ³)
Type of external material:	Stainless Steel
Type of internal material:	Polystyrene
Warranty:	3 / 5 years
Approvals	ETL C&US;ETL SANITATION

Refrigeration Data

Current absorbed:	3 Amps
Compressor power:	1/4 hp
Operating temperature min.:	32 °F
Operating temperature max.:	41 °F
Condenser type:	Fin & tube
Defrost type:	Auto Defrost

Sustainability

Refrigerant type:	R290
Refrigerant weight:	100 g