



Project _____

Item # _____

Quantity _____

Toast-Qwik® Electric Conveyor Toasters

Model: TQ3-20, -20H

Hatco's next generation of Toast-Qwik® Conveyor Toasters have been designed to provide a great look, and increased production capabilities. They continue to provide the best reliability, flexibility and value of any conveyor toaster available!

Standard features

- Patented ColorGuard Sensing System continually monitors chamber temperature and adjusts the chamber to ensure consistent toast results – even in your busiest periods
- Power Save mode activates manually by pressing the Power Save Button above the leaf symbol, which reduces power by 50%
- Features an Air Intake Filter Screen which is removable for easy cleaning
- Crumb tray is removable
- 2" (51 mm) high opening for standard unit
- 3" (76 mm) high for H unit, which is better for use with thicker breads and rolls
- DC stepper motor provides wide range of linear and precise speed control
- TQ3-20 and TQ3-20H produce between 600-700 slices of toast per hour
- Double-sided or single-sided toasting at the touch of a button



Air Intake Filter Screen

Power Save mode button above leaf symbol

Options (available at time of purchase only)

Designer Colors

Non-standard colors are non-returnable – Designer Black standard

Warm Red Stainless Steel

Stainless Steel toast tray insert

Extended feed ramp in lieu of existing ramp – adds 3" (76 mm)

XL extended feed ramp in lieu of existing ramp – adds 9" (229 mm)

IFS anti-microbial coatings use naturally-occurring, environmentally sustainable, silver ions to help inhibit the growth of microbes on the powder coated surface. See www.hatcocorp.com/antimicrobial-paint for more information.

For operation, location and safety information, please refer to the Installation and Operating Manual.



HATCO CORPORATION

P.O. Box 340500 Milwaukee, WI 53234-0500 U.S.A. | (414) 671-6350



www.hatcocorp.com

support@hatcocorp.com

[Find a Hatco Rep](#)

[Image Library](#)

[Document Library](#)

[Patents](#)

[Chat](#)



Toast-Qwik® Electric Conveyor Toasters

Model: TQ3-20,-20H

TQ3-20, -20H

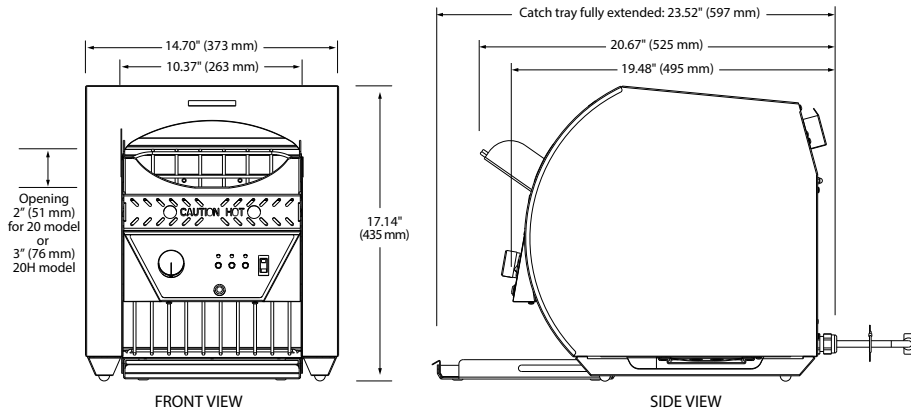

SPECIFICATIONS Toast-Qwik® Conveyor Toasters

Model	Opening Dimensions (W x H)	Dimensions (W x D x H)	Volts Single Phase	Hertz	Watts	Amps	Plug	Approx. Ship Weight
TQ3-20	10.37" x 2" (263 x 51 mm)	14.70" x 20.67" x 17.14" (373 x 525 x 435 mm)	208	50/60	2470	11.9	NEMA 6-15P	54 lbs. (25 kg)
			240			10.3		
TQ3-20H	10.37" x 3" (263 x 76 mm)	14.70" x 20.67" x 17.14" (373 x 525 x 435 mm)	208	50/60	2620	12.6	NEMA 6-20P	54 lbs. (25 kg)
			220	60	2397	11.9	NEMA 6-15P	
			240	50/60	2620	10.9		

CORD LOCATION

Lower right corner on back of unit.

PLUG CONFIGURATIONS

NEMA 6-15P

NEMA 6-20P

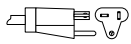
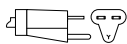

PRODUCT SPECS Toast-Qwik® Electric Conveyor Toasters

The electric Toast-Qwik® Conveyor Toaster with patented ColorGuard Sensing System shall be a Hatco model ... as manufactured by the Hatco Corporation, Milwaukee, WI 53234 U.S.A.

The toaster shall have the capacity to toast up to ... pieces per hour and it shall be rated at ... kW, ... volts, single phase. The toaster shall be of powdercoated steel

design and shall include double- or single-sided toasting capabilities, manual power save mode, a removable/cleanable air intake filter screen, and variable speed control. The toaster will have metal sheathed heating elements and factory attached UL listed cord and plug.

Warranty consists of 24/7 parts and service assistance (US and Canada only).

HATCO CORPORATION | P.O. Box 340500 Milwaukee, WI 53234-0500 U.S.A. | (414) 671-6350



www.hatcocorp.com | support@hatcocorp.com | [Find a Hatco Rep](#) | [Image Library](#) | [Document Library](#) | [Patents](#) | [Chat](#)