

BASE MODEL SANDWICH UNIT

Model: RA6N10-D

Natural Refrigerant R-290 Model

60" Standard Top Sandwich Unit Refrigerator with Drawers - 10 Pans

Heavy gauge #300 series stainless steel top, stainless steel front and end panels, galvanized steel rear and grills and aluminum interior.



Options and Accessories

(upcharge and lead times may apply)

| | |
|---|--|
| Stainless steel interior | Composite cutting board |
| Stainless steel back | Rear mounted cutting board |
| Overshelves (single or double) | Condensing unit left (standard on right) |
| Flat insulated night cover | Adjustable legs |
| Door & drawer locks | Front breathing |
| Vision panel lid | |
| Drawer in lieu of door section above the condensing unit* | |

Consult factory for other model configurations, options and accessories.

*Drawer section above condensing unit holds (1) 12 x 20 x 6 pan.

Continental
Refrigerator

Toll-Free: 800-523-7138
Phone: 215-244-1400
Fax: 215-244-9579

539 Dunksferry Road
Bensalem, PA 19020
www.continentalrefrigerator.com

Project Name:

Model Specified:

Location:

Item No:

Quantity:

AIA #:

SIS #:

Standard Model Features

REFRIGERATION SYSTEM

Performance rated refrigeration system

Natural, environmentally safe, high efficiency R-290 refrigerant¹

Unique forced air design utilizes fans (approx. every 12") across the entire back of unit for even distribution of cold

Automatic, hot gas condensate evaporator

Non-corrosive, plasticized fin evaporator coil

Easily serviceable, slide out condensing unit

Expansion valve system

CABINET ARCHITECTURE

2" non-CFC polyurethane foam insulation

Smooth, polished chrome door & drawer handles

Spring loaded, self closing door over condensing unit

Magnetic snap in Santoprene™ door gaskets

Stainless steel roll out drawers

12" deep, full length nylon cutting board

Insulated lid

5" casters

MODEL FEATURES

Refrigerated section with door above the condensing unit

(10) 1/6 size recessed pans, 4" deep

Electronic control, off-cycle defrost

Field rehingeable door over condensing unit

¹ R-290 refrigerant meets all federal and state regulatory requirements.

NOTE: Models come standard with a door above the condensing unit. A drawer above the condensing unit is an option.

APPROVAL:

Model Specifications

DIMENSIONAL DATA

| | |
|--|-----------------|
| Net Capacity (cubic feet) | 19 (538 cu l) |
| 1/6 Size Pans (4" deep) | 10 |
| Width, Overall (inches) | 60 (1524 mm) |
| Depth, Overall (inches) (including handles & bumpers) | 37 (940 mm) |
| Depth, Cutting Board (inches) | 12 (305 mm) |
| Height, Overall (inches) (including 5" casters) | 42 (1067 mm) |
| Number of Drawers | 4 |
| Number of Half Doors | 1 |
| Interior Depth (inches) | 30 (762 mm) |
| Interior Height (inches) (smaller section) | 26 (660 mm) |
| Interior Height (inches) (above condenser) | 12 1/2 (318 mm) |
| Interior Width (inches) (smaller section) | 17 (422 mm) |
| Interior Width (inches) (above condenser) | 17 (422 mm) |

REFRIGERANT DATA

| | |
|-----------------------------|------|
| Condensing Unit Size (H.P.) | 1/3+ |
| Capacity (BTU per hour)* | 2600 |

ELECTRICAL DATA

| | |
|--|---------------------|
| Voltage (International) | 115/60/1 (220/50/1) |
| Total Amps (International) | 5.8 (3.9) |
| 10 ft. Cord/Plug [attached] (International) | Yes (No) |

SHIPPING DATA

| | |
|--------------------------|------------------|
| Weight (pounds) | 420 (191 kg) |
| Height - Crated (inches) | 43 3/4 (1111 mm) |
| Width - Crated (inches) | 62 (1575 mm) |
| Depth - Crated (inches) | 47 (1194 mm) |

DRAWER PAN CONFIGURATIONS

Two Tier: (1) 12 x 20 x 6 pan & (3) 1/6 x 6 pans (top)
(2) 12 x 20 x 6 pans (bottom).
Three tier not available.

Two Narrow: (1) 12 x 20 x 6 pan per drawer (supplied by others)



Equipped with one NEMA-5-15P Plug
(varies by country)

* Rating @ +25°F evaporator,
90°F ambient

Figures in parentheses reflect
metric equivalents rounded to the
nearest whole unit

Model Plan Views

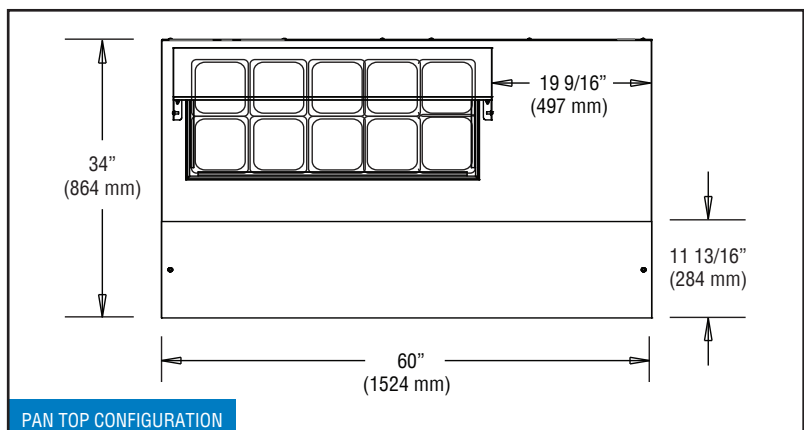
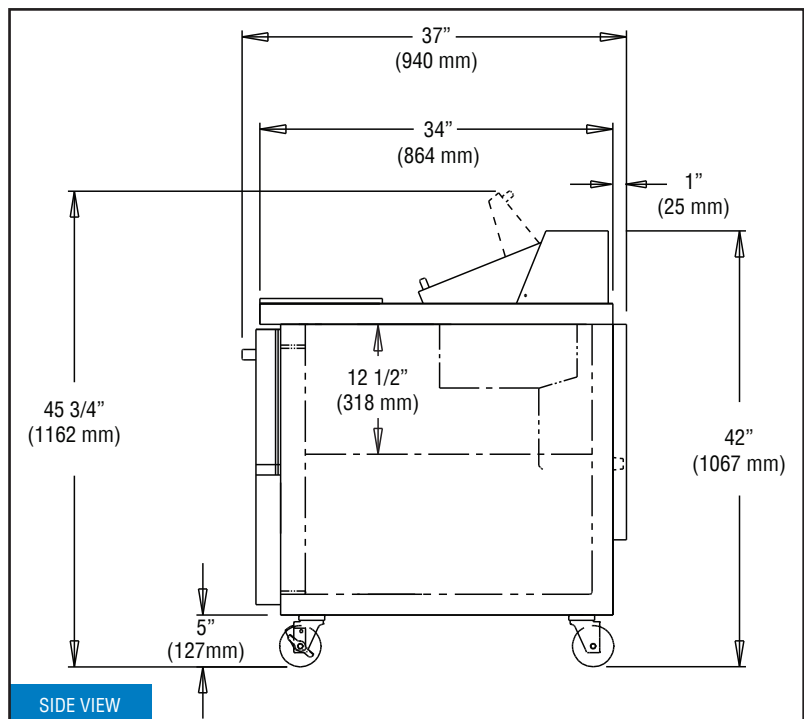
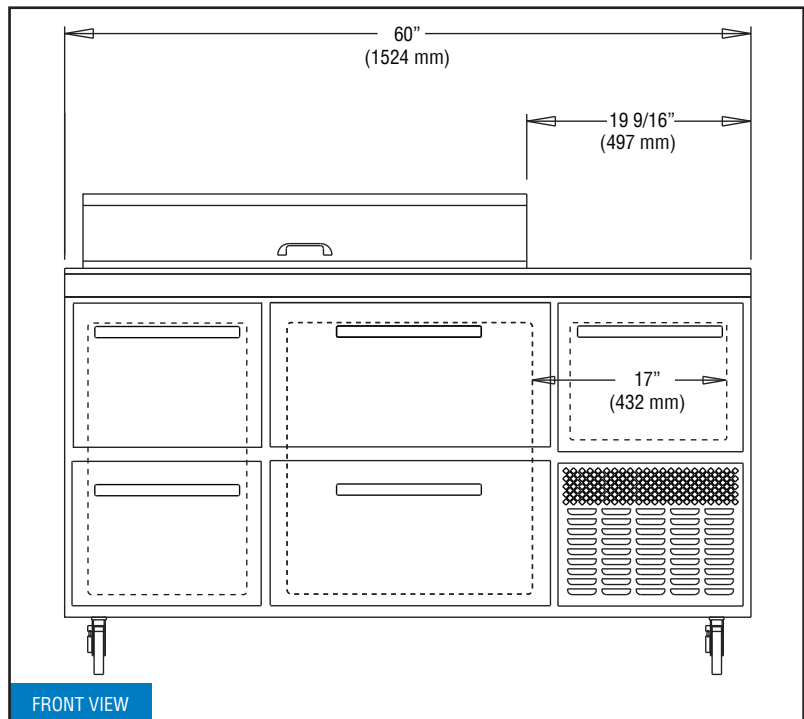

Continental[®]

Refrigerator

Toll-Free: 800-523-7138
Phone: 215-244-1400
Fax: 215-244-9579

539 Dunksferry Road
Bensalem, PA 19020
www.continentalrefrigerator.com

Due to our continued efforts in developing
innovative products, specifications subject
to change without notice.

