



BEVERAGE-AIR

Project: _____	AIA#
Item: _____	
Location: _____	SIS#
Approved: _____	

PH2 P SERIES WARMING CABINET

P SERIES TOP MOUNT WARMING CABINET
 PH2 Glass Door Warming Cabinet

**MODEL:
PH2-1BG**



7 Year Parts/Labor Warranty

CABINET CONSTRUCTION

- Exterior stainless steel front and side (galvanized top and bottom)
- Interior is made of corrosion resistant aluminum
- Stainless steel breaker caps
- Full electronic control
- Operational indicator panel contains thermometer and adjustable thermostat control which is accurately calibrated from 80°F to 180°F
- Built-in, adjustable humidity control vent
- Safety shield strip type heating elements
- External mounted blower maintains even temperatures
- Heavy-duty cylinder locks
- Self-closing doors with 120° hold open feature, with cam-lift hinges
- One-piece, snap-in magnetic door gasket
- Hinged front shroud
- Proximity door switch activates interior incandescent lighting
- 6" Adjustable legs
- Six (6) silver freeze shelves
- 8' Cord and plug (see electrical data for details)

OPTIONS & ACCESSORIES

- Pan slides
- Stainless steel interior
- 3" or 6" Casters
- Left or right door hinge (at time of order)

ELECTRICAL SYSTEM

- 20 AMP breaker required for double door units
- Strip type 750-watt heating elements, operating on 208-240/60/1, having a total of 1500 watts per compartment
- Externally mounted blower system maintains even temperature through out the food zone area



Please verify qualifying units by visiting:
www.energystar.gov/cfs

3779 Champion Blvd., Winston-Salem, NC 27105
1-888-845-9800 Fax: 1-336-245-6453
Beverage-Air.com Sales@bevair.com



BEVERAGE-AIR®

MODEL	PH2-1BG
EXTERNAL DIMENSIONAL DATA	
Width Overall	52 1/8"
Depth Overall with Handle	33 3/8"
Height Overall	84 1/8"
Number of Doors	2
Depth with Door Open 90°	56 5/8"
Door Openings (in)	21 1/2" x 54 5/8"
INTERNAL DIMENSIONAL DATA	
NET Capacity (cubic ft.)	46.5
Internal Width Overall (in)	48 1/8"
Internal Depth Overall (in)	26"
Internal Height Overall (in)	55 3/4"
Number of Shelves	6
ELECTRICAL DATA	
Amps	13.0
Cabinet Voltage 208-240/60/1	208-240/60/1
Heater Watts per Section (@240V)	3000
SHIPPING DATA	
Gross Weight - Crated	450 lbs
Height - Crated	85"
Width - Crated	55"
Depth - Crated	39"

We reserve the right to change specifications and product design without notice. Such revisions do not entitle the buyer to corresponding changes, improvements, additions or replacements for previously purchased equipment. Dimensional tolerances +/- 1/4". Metric dimensions (MM).

Top Mount Warming Cabinet Reach-In Model: PH2-1BG

Model Views

Required Clearance: Top 12"

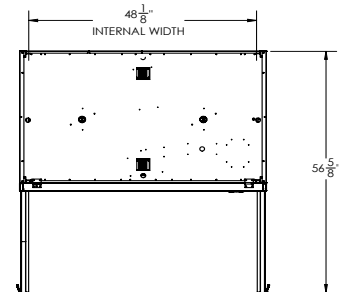

PLAN VIEW

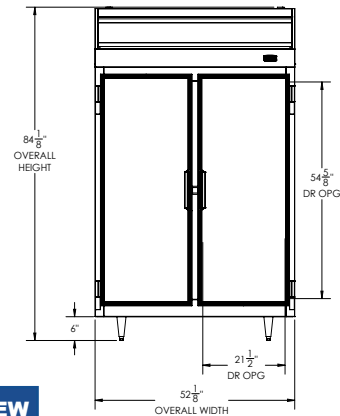

ELEVATION VIEW

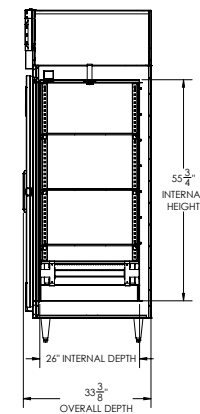

SIDE VIEW



ELECTRICAL CONNECTION



208-240/60/1
NEMA 6-20P

Unit pre-wired at factory and include 8' long cord and plug set.