



Scan for more info!

Owners Manual
Quick Install
Quick Sizing
Install Layout
Parts List

CR-24FCP
30,000 Gallon Filtering Capacity System



Compact size fits under the counter

Advanced Fibredyne media technology cartridges offer superior reduction in Chlorine, Taste, Odor, Color and Organic Chemicals while providing exceptional sediment reduction with resistance to premature plugging. This submicron technology is NSF certified to reduce particles as small as 1/2 micron in size which reduces health contaminants such as Cysts

Specifications

- 2 Stage System
- 10" Pleated Cellulose Pre-filter
- Two 4FC High Capacity Cartridges
 - Advanced Fibredyne technology
 - Quick Change sanitary cartridge
 - Recyclable
 - High Capacity, Extended filter life
- Certifications: NSF 42 Class I and NSF 53
- Flow Rate: 5 GPM
- Rated Capacity: 30,000 Gallons
- Inlet Connection: 3/4"
- Outlet Connection: 3/4"
- Pressure Requirements: 40-125 psi
- No Electrical connection
- Manifold features water shut-off, flushing valve and water pressure gauge
- 21.59"W x 6.13"D x 19.25"H

System Tested and Certified by NSF International against NSF/ANSI Standard 42 and 53 for the reduction of:

Std. No. 42 -

Aesthetic effects

Bacteriostatic Effects

Chemical Reduction

Taste & Odor

Chlorine

Mechanical Filtration

Nominal Particulate Class I

Std. No. 53 -

Health effects

Mechanical Filtration

Turbidity

Cyst

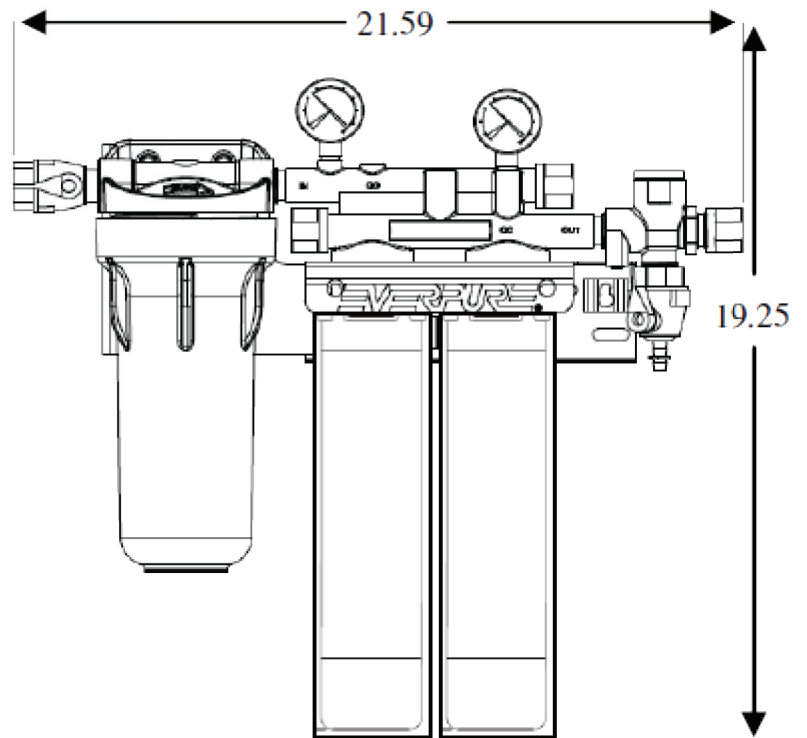

2.06.14

Features & Benefits:

- Increased capacity for extended reduction of chemical and mechanical contaminants
- Balanced cartridge for optimum performance in varying water qualities
- New Fibredyne II media with AglON antimicrobial protection inhibits any potential bacterial growth
- Reduces chlorine taste and odor and other offensive contaminants that can adversely affect the taste of beverages
- Improves the taste of fountain beverages and helps retain the drink's carbonation
- Submicron technology reduces dirt and particles as small as 1/2 micron in size, and reduces health contaminants such as Cryptosporidium and Giardia cysts
- Protects drink system seals, pump, tubing and small orifices from clogging, corrosion and abrasive wear
- Sanitary cartridge replacement is simple, quick and clean. Internal filter parts are never exposed to handling or contamination, and used filters are recyclable
- Fibredyne technology creates a unique filter media by attaching powdered activated carbon onto a cellulose-free synthetic fiber matrix
- Benefits of this technology include low pressure drop over the entire life of the cartridge and up to three times the chlorine taste & odor and dirt-holding capacity of traditional 2 or 3 stage carbon block filter systems
- In addition, Fibredyne's technology will not release fines into the effluent stream due to a unique post-filtration layer that is fused to the carbon/fiber media blend



NSF Certified under NSF/ANSI Standard 18

