

Project: \_\_\_\_\_ Location: \_\_\_\_\_ Item #: \_\_\_\_\_ Quantity: \_\_\_\_\_

### Standard Features

- Fast cook times with patented Steam Vector Technology, which utilizes no moving parts
- Cook mode and Variable Hold Temperature mode
- Easy-to-use digital controls with digital temperature display
- Independent digital electronic timer with programmable preset
- Simple water and drain connections
- No water filtration or treatment required
- No warranty exclusions for water quality
- Uses less than 1.5 gallons of water per hour
- Front-mounted drain valve
- No scheduled de-liming or maintenance
- Heavy-duty, field-reversible door
- Door can be opened at any time during cooking cycle
- Cast aluminum heating element is not exposed to water
- Multiple kW heat inputs available for all cooking needs
- Steamer cavity constructed of reinforced 14 ga. 304 stainless steel
- Easy-to-clean control panel
- Automatic altitude compensation
- Dishwasher-safe one-piece wire pan racks
- Dishwasher-safe SVT steam collector and distributor panels (6 pan only)
- Dishwasher-safe front-mounted condensate tray
- Operating instructions on door
- Simplified service access panel
- Low water, high water and overtemp indicator lights
- (2) 5' power cord with plug included
- No hood required (in most states)
- One year parts and labor warranty
- Lifetime Service & Support Guarantee
- UL LISTED Safety Certification (UL 197)
- UL EPH Sanitation Certification (NSF 4)
- Stainless steel support stand available with casters, bullet feet or flanged feet

### Optional Features

- Bullet Feet
- Perforated cooking shelf

### Safety, Sanitation & Environmental



- EPA 202 Evaluated / NFPA 96 4.1.1.2 Compliant



### Pan Capacities

Pan Size	Qty.
#200 full size (12x20x2.5")	9
#400 full size (12x20x4")	6

### Short Spec

Evolution™ steamer is AccuTemp Products' connected, boilerless steam cooker that utilizes AccuTemp's patented Steam Vector Technology for faster cook times, improved energy efficiency, better pan to pan uniformity, and less water consumption. Steam Vector Technology requires no moving parts inside the cooking chamber. Steam to be produced inside the cooking cavity with no heating element exposed to water. Easily connects to water and drain line. Uses less than 1.5 gallons of water per hour. Unit to include low water, high water, overtemp warning lights and auto shut off feature. Evolution™ to include heavy duty, field reversible door. Standard digital controls with independent timer. No water quality exclusions to warranty and no water filtration or treatment required. Unit to be UL Safety and Sanitation Certified, and 6 Pan is Energy Star qualified. Built in USA.



E3 Evolution™ Model shown stacked with E6 model on stand with casters

Steamer Model "E" Specifications per cavity* DBL = TWO CAVITIES						
Model #	E3/E62081E060 DBL	E3/E62083E150 DBL	E3/E62403E110 DBL		E3/E64803E140 DBL	
Volts AC	208	208	208	240	440	480
Phase	1	3	3		3	
Amps	29	42	22	26	16	17
Breaker Size	30 amp	50 amp	30 amp		20 amp	
Watts (kW)	6	15	8	11	12	14
NEMA Plug	L6-30P	15-50P	L15-30P		L16-20P	

Notes:

1. Allow 3" between fryer, ranges, and other hot surfaces.
2. (2) 5' power cord supplied with single or 3 phase.
3. For use on individual branch circuit only.
4. Do not connect to a circuit operating at more than 150V to ground.
5. Dimensions outside brackets are inches, in brackets are millimeters.
6. Each unit equipped with 3/4" male garden hose connector
7. Each unit equipped with 3/4" barbed drain line connector
8. DO NOT plumb a single drain line between 2 units. Each unit must have a separate drain line.

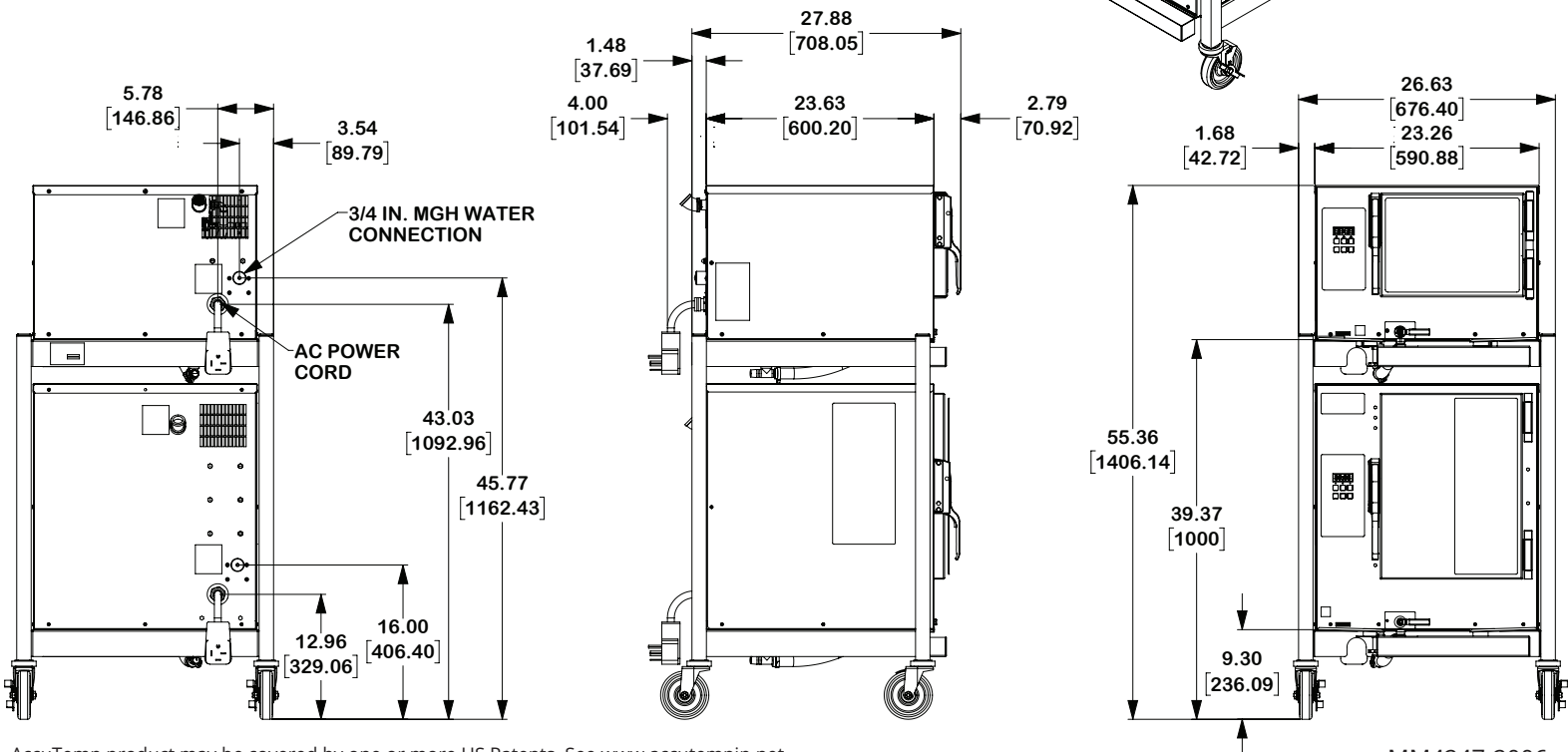
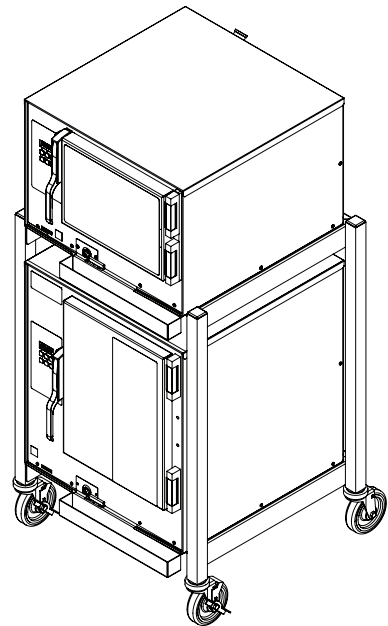
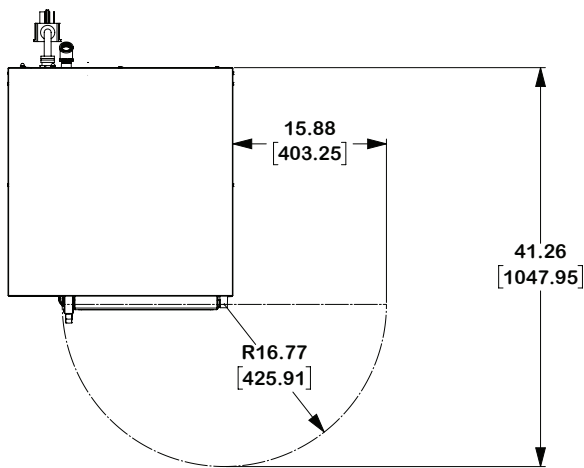

AccuTemp product may be covered by one or more US Patents. See [www.accutempip.net](http://www.accutempip.net)

MM4247-2006

AccuTemp Products, Inc.

8415 North Clinton Park • Fort Wayne, IN 46825 • 800-210-5907 • 260-493-0415 • Fax 260-493-0318 • [accutemp.net](http://accutemp.net)