



SINGLE WELL, HEAVY DUTY, TOP MOUNT, RECTANGULAR DROP-IN FOOD WARMERS

MODELS: HFW-43S



APW Wyott heavy-duty, top-mount, drop-in, modular food warmers are designed to hold heated foods at safe and fresh serving temperatures. Extra Deep, 12 X 27, 4/3rd Pan Models are available in one well models. And accommodates 4 each 1/3 Size pans per well or equivalent fractional inset pans and are designed for wet or dry operation.

One-piece stainless steel top flange and heavy-gauge, deep-drawn stainless steel warming pans are standard features on all models. E-Z Locks are standard for quick and easy installation.

Sides, front, back and bottom are fully insulated for energy savings, efficiency, quicker pre-heat and faster recovery.

Individual controls for each well provide maximum versatility. Extra deep models feature thermostatic controls. High-limits prevent overheating. Temperature-ready indicator lights are standard. Powerful tubular heating elements are located under the warming pans for quick and efficient heating and for even heat distribution.

OPTIONS

- Adaptor tops for round insets
- Drain valve extension kit
- Drain screens
- E-Z Lock extension kits for wood counter installations
- Optional 72" wiring

WARRANTY

- 1-Year Limited Parts & 1-Year Limited Labor Warranty

CERTIFICATIONS

Certified by the following agencies:



FEATURES AT A GLANCE

- Accommodates 4 each 1/3rd size inset pans per well or equivalent fractional pans
- One-piece stainless steel top flange and heavy-gauge, deep-drawn stainless steel warming pans
- Suitable for wet or dry operation (wet recommended for best results)
- Energy-saving fully-insulated construction
- Fully Insulated models are perfect for non-metal counters
- Thermostatic controls
- Separate controls for each individual well
- High limits prevent overheating
- Thermostatic controls are recessed in a one-piece, drawn, front-mounted panel
- E-Z Locks are standard for ease of installation
- Powerful tubular heating elements

EQUIPMENT DIMENSIONS

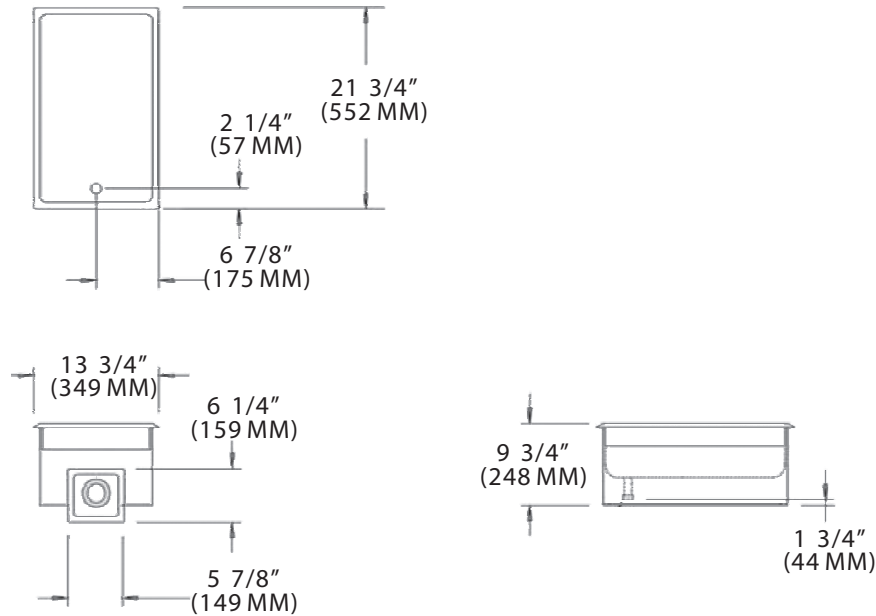

MECHANICAL SPECIFICATIONS

Model #	Drain	Watts	Voltage	Phase	Overall Dimensions	Control Panel Dimensions	Ship Weight (lbs. / Kilos)	Crate Size	Approvals
					Width x Height x Depth (inches / mm)	Width x Height (inches / mm)		Cubic Feet (Cubic Meters)	
HFW-43	Yes	1240 1650	208 240	1	14.75" x 30.50" x 9.75" (375 x 775 x 248)	14 x 6.25 (355 x 159)	25 (12)	10.55 (0.299)	NSF UL

REQUIRED CLEARANCES

Left	1" (25mm)	Back	1" (25mm)
Right	1" (25mm)	Bottom	6 3/4" (171mm)
Front	4 1/8" (105mm)		

Freight Class: 100
 FOB: Smithville, 37166

APW Wyott reserves the right to modify specifications or discontinue models without incurring obligation. Dimensions nominal.