



FEATURES

- Oil lubricated rotary vane vacuum pump, nominal speed 423 cf/h (12 m³/h);
- Vacuum level control through high precision sensor;
- Maximum vacuum 99,8% (2 millibar);
- 12,4" sealing bar, easily removable for cleaning with standard double sealing;
- Hydroformed, brilliant stainless steel vacuum chamber with constant thickness, easy to clean being free of edges and receptacles;
- Standard inert gas injection with 2 injection nozzles;
- Waterproof stainless steel digital control panel, with control board and vacuum sensor protection cover;
- 20 editable user programs, with assignable names from keyboard; 5 settable display languages;
- 8 preset cycles for specific types of food to be preserved or processed ("chef" cycles);
- 5 deaeration cycles for solid and liquid food processing or food preservation ("chef" cycles);
- 2 generic preset cycles for preservation or sous vide cooking;
- Specific cycle for vacuum containers;
- Pump oil dehumidification cycle "H2Out"
- Menu accessible to technical assistance for parameter setting and adjustment with resettable oil change alarm;
- High-thickness blued PMMA (Plexiglass) lid with polished and rounded edges and chromed aluminum alloy die-cast hinges, over-opening from 60 ° to 90 ° for easy cleaning;
- Removable aluminum silicone holder bar, which allows easy cleaning and sanitizing of the vacuum chamber (patented);
- Front opening of the machine body to facilitate access to maintenance;
- High welding pressure (over 150kg with 99% vacuum) operating on the sealing bar; with thermal welding protection system;
- Standard "Easy" accessory for external vacuum in embossed bags and 3 PE-filling plates for product adjustment and cycle speed up;

DESCRIPTION

Made of AISI304 stainless steel, the Bright line models features a high quality level and extreme care of every detail, which reflects into robustness, reliability and safety. They are equipped with advanced functional and technological features such as deaeration cycles, preset cycles based on the type of food to be vacuum packed, inert gas injection, double sealing. Removable silicon holder and front opening of the casing are some of the construction features designed to facilitate cleaning, maintenance and reduce operating costs.

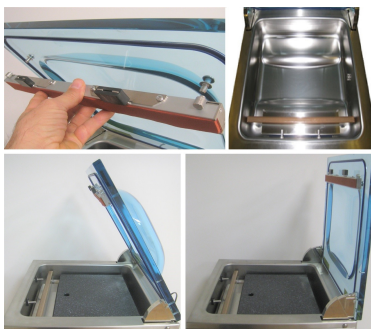

SEALING BAR 12.4 inch
VACUUM PUMP 423 cf/h
SENSOR CONTROL

OPTIONALS

- "Softair" air return at the end of the cycle;
- Cut-off seal

ACCESSORIES (NOT INCLUDED)

- Bags for storage, cooking and "cook & chill"; embossed bags;
- Stainless steel cart with castors and shelf
- Inclined stainless steel plate for liquid packing



Intertek Intertek

According to:

UL197 / NSF Hygienic standards

PROJECT	DATE	APPROVED
ITEM	QTY	

VACUUM PACKAGING MACHINES VM16N

UPDATED:
27/07/2021

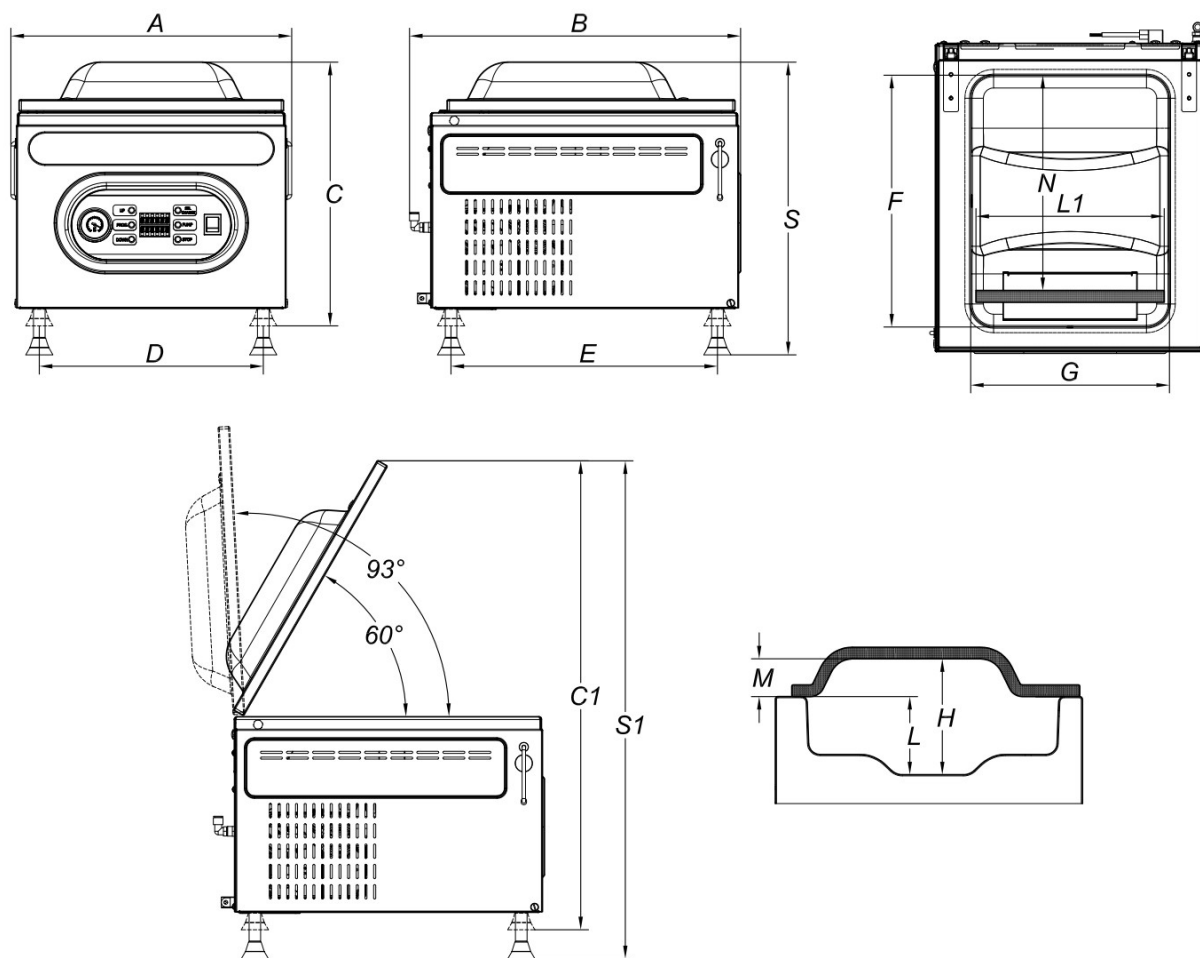

SPECIFICATIONS

Length of seal L1	inch	12,4
Nominal pump speed	cf/h	423
Final pressure	mbar	2
Chamber size (FxBxH)	inch	17,1x13,5x7,9
Useful chamber space (N)	inch	14,6
Chamber depth (L)	inch	5,3
Chamber volume	Usgal	7,128
Power	W	900
Electrical voltage/Frequency/Phases	V/Hz	110V / 60Hz / 1Ph+N+PE
Power cord and plug		78,7 inch / Nema 5
Current	A	8,18
Housing materials		Stainless steel (AISI304)
Vacuum chamber material		Hydroformed stainless steel (AISI304)
Lid material		PMMA (plexiglas)
Overall dimensions (AxBxC)	inch	19,1x22,5x17,9
Overall dimensions (AxBxS)	inch	19,1x22,5x19,9
Maximum height with open lid (C1)	inch	31,9
Maximum height with open lid (S1)	inch	33,8
Distance between supports (DxE)	inch	15,2x18,1
Weight (with filling plates)	lbs	114,6
Noise level	dB(A)	62
Environmental operating temperature (min-max)	°F	53,6-104