



Project _____
 AIA # _____ SIS # _____
 Item # _____ Quantity _____ C.S.I. Section 114000

UST SERIES

Compact Sandwich Prep Tables with Flat Cover/Self-Contained



Intertek



This unit is listed to the applicable ETL and NSF Standards by an approved NRTL. Consult the factory or unit's data plate for approval information.

AVAILABLE CONFIGURATIONS

72" Wide Models

Model	Model Type	Hinging
UST7212-LR	72" Wide 12 Pan	Left/Right
UST7212-LL	72" Wide 12 Pan	Left/Left
UST7212-RR	72" Wide 12 Pan	Right/Right
UST7218-LR	72" Wide 18 Pan	Left/Right
UST7218-LL	72" Wide 18 Pan	Left/Left
UST7218-RR	72" Wide 18 Pan	Right/Right
UST7224-LR	72" Wide 24 Pan	Left/Right
UST7224-LL	72" Wide 24 Pan	Left/Left
UST7224-RR	72" Wide 24 Pan	Right/Right
UST7230-LR	72" Wide 30 Pan	Left/Right
UST7230-LL	72" Wide 30 Pan	Left/Left
UST7230-RR	72" Wide 30 Pan	Right/Right

STANDARD PRODUCT FEATURES

- High Quality Stainless Steel Exterior Top, Sides & Door(s)
- Durable, Corrosion Resistant Anodized Aluminum Interior
- Provides NSF Standard 7 Performance, Even When Using 6" Deep Pans
- Standard Work Height 34³/₈" on 4" casters
- Environmentally Friendly, Low GWP R-290 Refrigerant
- Top Cut-Outs Accommodate Sixth Size Pans (divider bars and 4" deep plastic sixth size pans provided)
- Reinforced Pan Ledge (holds pans securely level)
- Reversible, Full Length White Nylon Cutting Board
- Self-Closing Stainless Steel Doors with Convenient Stay-Open Feature at 105 Degrees
- Electronic Control
- Two (2) Powder Coated Steel Shelves Per Door, Mounted on Adjustable Pilasters
- Set of Six (6) 4" Casters
- Magnetic Snap-In EZ-Clean Door Gasket(s)

ACCESSORIES & OPTIONS (*field installed)

- CK21 (six 6" (15.2cm) high casters for 72" models)
- CK25 (six 3¹/₂" (8.9cm) high casters for 72" models)
- CK27 (six 2³/₄" (6.9cm) high casters for 72" models)
- LK6 (six 6" (15.24 cm) high legs for 72" models)
- SHELF72 UPPER (upper shelf for 72" models)
- SHELF72 LOWER (lower shelf for 72" models)
- Optional accessory kits shipped separately for field installation

FACTORY INSTALLED OPTIONS

- Stainless Steel Finished Back (model numbers will have '-SB' suffix)

- GUARANTEED FOR LIFE WORKFLOW DOOR HANDLES

DEALERS CHOICE PREP TABLES

Approved by _____ Date _____ Approved by _____ Date _____

MODEL:
UST7212-LR

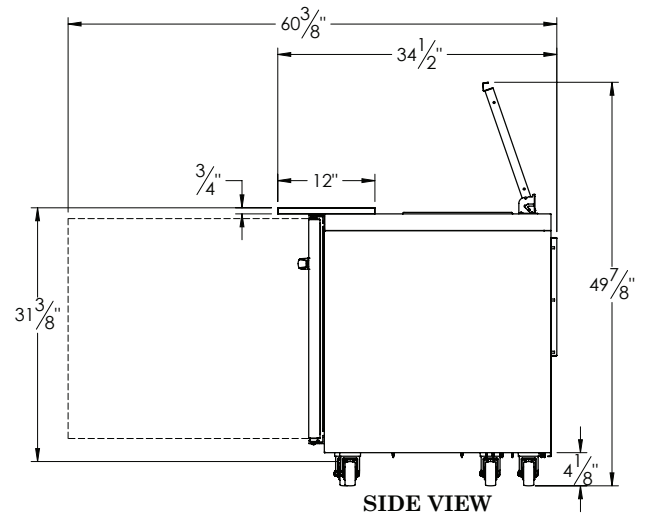
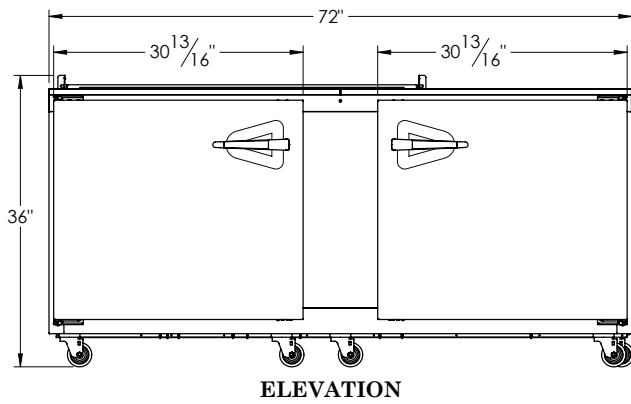
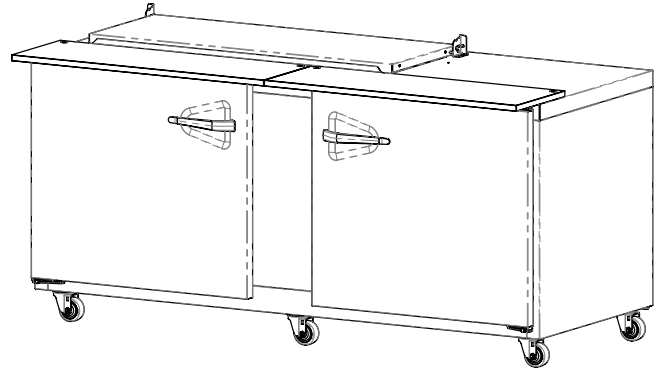
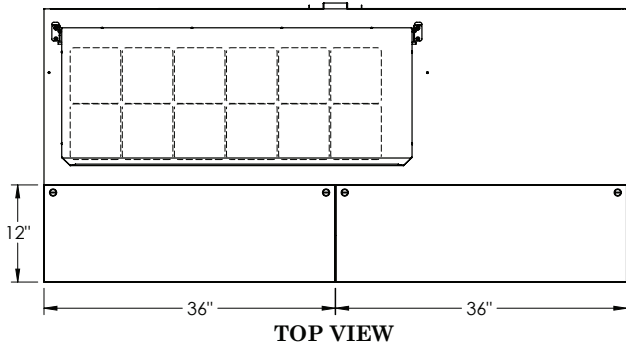

UST SERIES

Compact Sandwich Prep Table
Flat Cover/Self-Contained

MODEL:
UST7230-LR

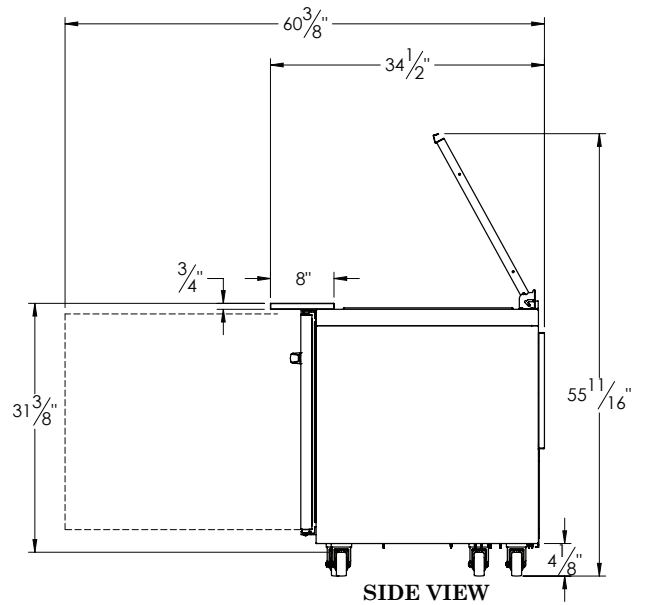
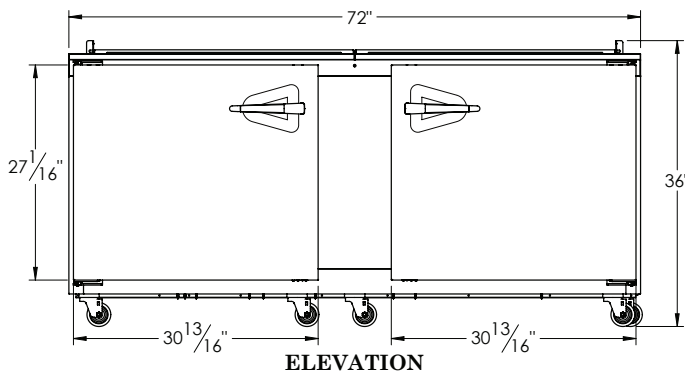
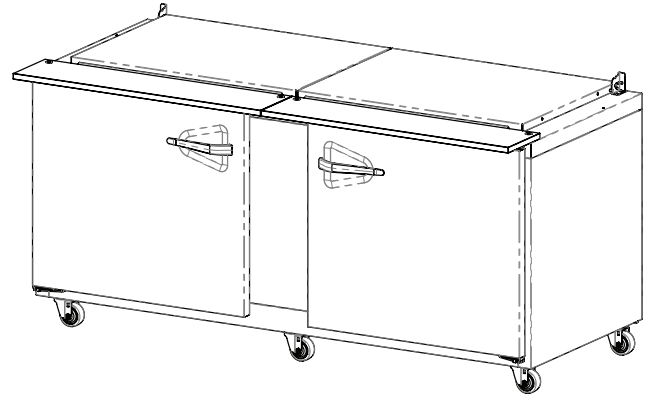
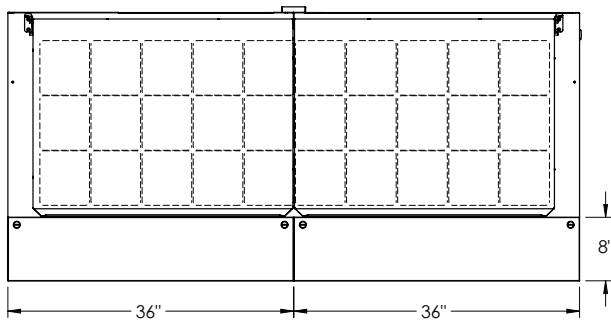



UST SERIES

Compact Sandwich Prep Tables

Flat Cover/Self-Contained

MODELS:

UST7212, UST7218, UST7224, UST7230

EQUIPMENT SPECIFICATIONS

MODELS	UST7212	UST7218	UST7224	UST7230
DIMENSIONAL DATA				
Net Capacity cu. ft.	24.5 (693.8 l)			
# of 1/6 Size Pan Top	12	18	24	30
Length - overall in.	72 (182.9 cm)			
Depth - overall in. ¹	34½ (87.6 cm)			
Depth - door open 90° in.	60¾ (153.4 cm)			
Clear door width in.	30 ¹³ / ₁₆ (78.3 cm)			
Clear door height in.	27 ¹ / ₁₆ (68.7 cm)			
Depth - cutting board in.	12 (30.5 cm)	8 (20.3 cm)		
Height - overall on 4" casters	36 (91.4 cm)			
Height with lid open in. ³	49 ⁷ / ₈ (124.7 cm)	55 ¹¹ / ₁₆ (141.5 cm)		
# of Doors	2			
# of Shelves	4			
Total Shelf area sq. ft	15.5 (1.4 m)			
ELECTRICAL DATA (NEMA 5-15P attached)				
Voltage	115/60/1			
Full Load Amperes	7.2			
REFRIGERATION DATA				
Refrigerant	R-290			
Refrigerant Amt oz.	5 (142 g)			
BTU/HR ² H.P.	1680 1/5 HP			
SHIPPING DATA				
Length - crated in.	84 (213 cm)			
Width - crated in.	42 (107 cm)			
Height - crated in.	41 (104 cm)			
Volume - crated cu. ft.	91 (2577 l)			
Weight - crated lbs.	408 (185 kg)			

NOTES:

1. Overall depth includes standard cutting board
2. Compressor BTU based on a 90°F ambient and 20°F evaporator
3. Height includes 4" casters

When ordering please specify: Voltage, Hinging, and Options.

Equipped with one NEMA 5-15P Plug



CONSTRUCTION, HARDWARE, INSULATION

Cabinet exterior front, sides, pan cover lid and doors are constructed of heavy gauge stainless steel. Cabinet interior and door liners are constructed of anodized aluminum. The exterior cabinet back at the bottom are constructed of galvanized steel.

Doors self close at less than 90 degrees and also includes a stay open feature at 105 degrees. Gasket profile and material simplify cleaning and increase overall gasket life.

Both the cabinet and doors are insulated with an average of 2" thick high density non-CFC, foamed in place polyurethane. A ¾" thick, full-length, reversible white nylon cutting board is supplied standard.

PANS & COVER

Each model is supplied standard with its full compliment of 4" deep plastic 1/6 size pans and stainless steel pan dividers. The lid is constructed of stainless steel, and is easily removable for cleaning.

REFRIGERATION SYSTEM

A balanced, rear mounted, front breathing, self-contained refrigeration system using environmentally friendly R-290 refrigerant is provided. It features a capillary tube metering device, air cooled hermetic compressor, a forced air evaporator coil and a non-electric condensate evaporator. An 8' cord and plug is provided. Standard operating temperature of the refrigerated base is 34° to 38°F (1.1° to 3.3°C).

CONTROLLER

An electronic digital control is supplied standard. It includes a 3-Digit LED display, and a Fahrenheit or Celsius temperature scale display capability.

INTERIOR

Standard interior arrangements include two (2) powder coated wire shelves per door, mounted on pilasters. These are adjustable in ½" (1.27 cm) increments, allowing for a minimum of 1½" (3.81 cm) spacing between shelves.

WARRANTY

Both a six year parts and labor warranty and a seven year compressor parts warranty (self-contained models only) are provided standard.

CONTINUED PRODUCT DEVELOPMENT MAY NECESSITATE SPECIFICATION CHANGES WITHOUT NOTICE.