

# SANDWICH UNIT REFRIGERATOR

## Model: SW32N8C-FB-D

Natural Refrigerant R-290 Model

32" Cutting Top Sandwich Unit Refrigerator with Drawers - 8 Pans Front Breathing

Stainless steel front, top and end panels, aluminum back and interior.



## Options and Accessories

(upcharge and lead times may apply)

Stainless steel interior	Rear mounted cutting board
Stainless steel back	Composite cutting board
Overshelves (single or double)	Flat insulated night covers
Drawer locks	Vision panel lids
Crumb catcher	Modified pan openings

Consult factory for other model configurations, options and accessories.

Project Name:

Model Specified:

Location:

Item No:

Quantity:

AIA #:

SIS #:

## Standard Model Features

### REFRIGERATION SYSTEM

Performance rated refrigeration system

Natural, environmentally safe, high efficiency R-290 refrigerant<sup>1</sup>

Unique air flow distribution allows pan product to maintain 33° - 41°F

Automatic, hot gas condensate evaporator

Non-corrosive, plasticized fin evaporator coil

Easily serviceable, back mounted compressor

### CABINET ARCHITECTURE

2" non-CFC polyurethane foam insulation

Smooth, polished chrome drawer handles

Stainless steel roll out drawers

Magnetic snap in Santoprene™ drawer gaskets

19" deep, full length nylon cutting board

Insulated lid

Completely enclosed, vented and removable case back

3 ¾" casters

### MODEL FEATURES

(8) ½ size recessed pans, 4" deep

Electronic controller with digital display & hi-low alarm

Off-cycle defrost

Removable interior tub below pans

<sup>1</sup> R-290 refrigerant meets all federal and state regulatory requirements.

Front breathers are a unique, field assembled, bottom mounted ventilation system designed to allow cabinets to be flush against a wall or built into a counter to conserve space. For proper operation, the area under and in front of the cabinet must not be obstructed in any way.

**Continental**<sup>®</sup>  
Refrigerator

Toll-Free: 800-523-7138  
Phone: 215-244-1400  
Fax: 215-244-9579

539 Dunksferry Road  
Bensalem, PA 19020  
[www.continentalrefrigerator.com](http://www.continentalrefrigerator.com)

APPROVAL:

# Model Specifications

## DIMENSIONAL DATA

Net Capacity (cubic feet)	9.0 (253 cu l)
1/6 Size Pans (4" deep)	8
Width, Overall (inches)	32 (813 mm)
Depth, Overall (inches) (including cutting board & bumpers)	38 1/4 (972 mm)
Depth, Cutting Board (inches)	19 (483 mm)
Height, Overall (inches) (including 3 3/4" casters)	41 (1041 mm)
Number of Drawers (two tier)	2

## REFRIGERANT DATA

Condensing Unit Size (H.P.)	1/5
Capacity (BTU per hour)*	1625

## ELECTRICAL DATA

Voltage (International)	115/60/1 (220/50/1)
Total Amps (International)	2.46 (1.85)
10 ft. Cord/Plug [attached] (International)	Yes (No)

## SHIPPING DATA

Weight (pounds)	236 (107 kg)
Height - Crated (inches)	43 1/4 (1099 mm)
Width - Crated (inches)	40 (1016 mm)
Depth - Crated (inches)	37 1/4 (946 mm)

## DRAWER PAN CONFIGURATIONS

**Two Tier:** (1) 12 x 20 x 6 pan per drawer  
or (1) 1/2 size x 6 & (2) 1/3 x 6 pans per drawer

\* Rating @ +25°F evaporator, 90°F ambient  
Figures in parentheses reflect metric equivalents rounded to the nearest whole unit.



Equipped with one NEMA-5-15P Plug  
(varies by country)

**Continental**  
Refrigerator

Toll-Free: 800-523-7138  
Phone: 215-244-1400  
Fax: 215-244-9579

539 Dunksferry Road  
Bensalem, PA 19020  
[www.continentalrefrigerator.com](http://www.continentalrefrigerator.com)

Due to our continued efforts in developing innovative products, specifications subject to change without notice.



© Copyright 2021. Continental Refrigerator.  
A Division of National Refrigeration & Air Conditioning Products, Inc.

# Model Plan Views

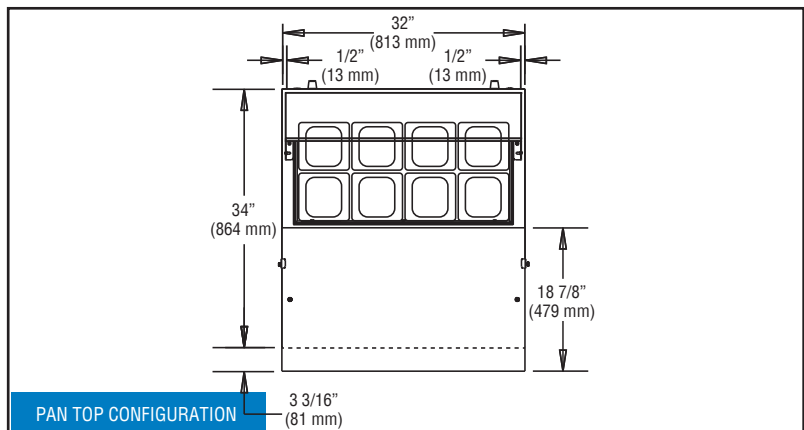
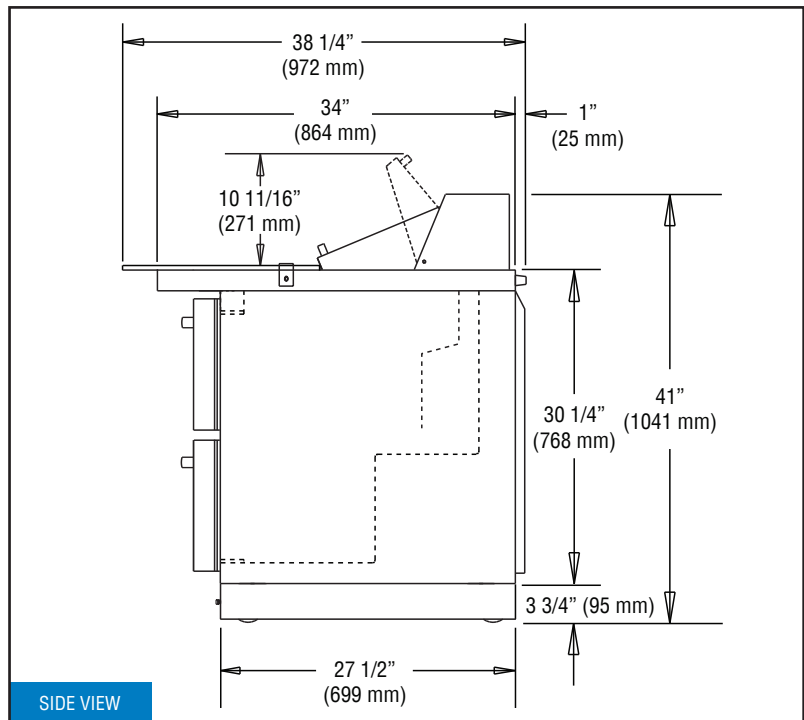
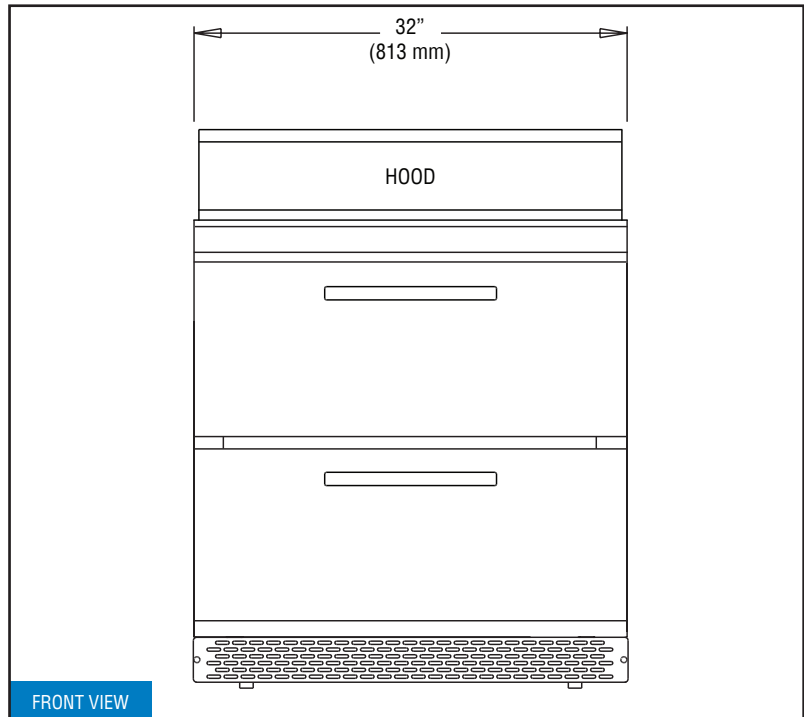

REVISED: 4/8/2022