



Project \_\_\_\_\_  
 AIA # \_\_\_\_\_ SIS # \_\_\_\_\_  
 Item # \_\_\_\_\_ Quantity \_\_\_\_\_ C.S.I. Section 114000

## A-Series

W-Width Reach-In Freezer Model  
 26" Deep, Self-Contained



### STANDARD PRODUCT FEATURES

- Traulsen's Smart Control with LED Display
- -10°F Capable in up to 100°F Ambient
- Stainless Steel Exterior/Anodized Aluminum Interior
- Balanced, Self-Contained Refrigeration System Using R-448A
- Full or Half-Height Stainless Steel Door(s) with Lock(s)
- Anti-Condensate Door Perimeter Heater
- Self-Closing Door with Stay Open Feature at 120 Degrees
- Standard Door Hinging: 126W = Right (other hings available)
- Automatically Activated LED Lights
- Stainless Steel Breaker Caps
- Three Adjustable, Coated Wire Shelves Per Section, Supported on Shelf Pins (factory installed)
- Automatic Non-Electric Condensate Evaporator
- Magnetic Snap-In EZ-Clean Door Gasket(s)
- Gasket-Protecting Raised Door Liner(s)
- Thermostatic Expansion Valve Metering Device
- Stainless Steel One-Piece Louver Assembly
- 9' Cord & Plug Attached
- Set of (4) 6" High Adjustable Stainless Steel Legs

### ACCESSORIES & OPTIONS

- Stainless Steel Finished Back with Rear Louvers
- Option to Relocate Electrical Box
- Optional Door Hinging
- Rehinging Feature for Door(s)
- Additional Coated Wire or Optional Stainless Steel Shelves
- Stainless Steel Banking Strip
- EZ-Open Foot Pedal (full-height doors only)
- Positive Action Latch (consult factory)
- Locking Hasps (padlocks supplied by others)
- Export 220/50/1 or 208-230/115 Voltages (consult factory)
- Kool Klad Exterior Laminate Decor (consult factory)
- Set of (4) 4 1/8" or 6" High Casters in Lieu of Legs
- 6" Stainless Steel Flanged Legs
- Other Support Options: 4 1/2" High Base in Lieu of Legs or 6" High Kickplate (for use with standard legs)
- Prison/Correctional Facility Options
- Heat Shield
- Remote Glycol Application (consult factory)



Intertek



This unit is listed to the applicable UL, CSA and NSF Standards by an approved NRTL. Consult the factory or unit's data plate for approval information.

### AVAILABLE CONFIGURATIONS

#### A-Series Models

ALT126WUT-FHS  
 ALT126WUT-HHS

#### Door(s)

Full Height Solid  
 Half Height Solid

**\*Remote application available,  
 see form TR35837 for details.**

**- GUARANTEED FOR LIFE CAM-LIFT HINGES  
 - GUARANTEED FOR LIFE HORIZONTAL WORK  
 FLOW DOOR HANDLES (SOLID DOORS ONLY)**

Approved by \_\_\_\_\_ Date \_\_\_\_\_ Approved by \_\_\_\_\_ Date \_\_\_\_\_

### MODEL

ALT126WUT-HHS  
ALT126WUT-FHS

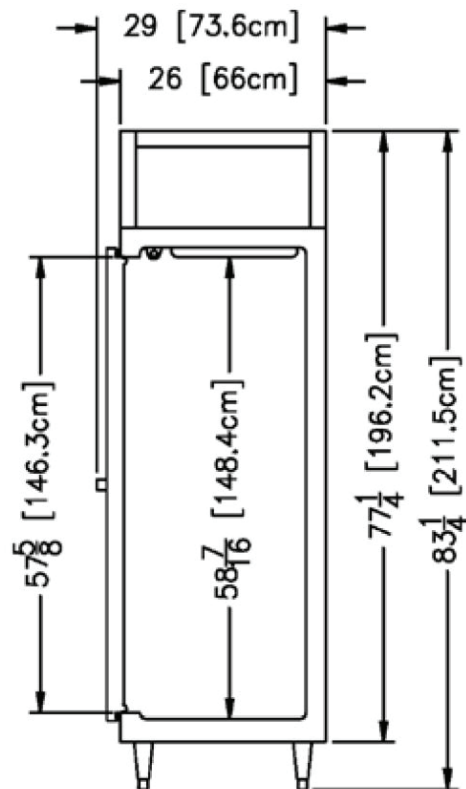
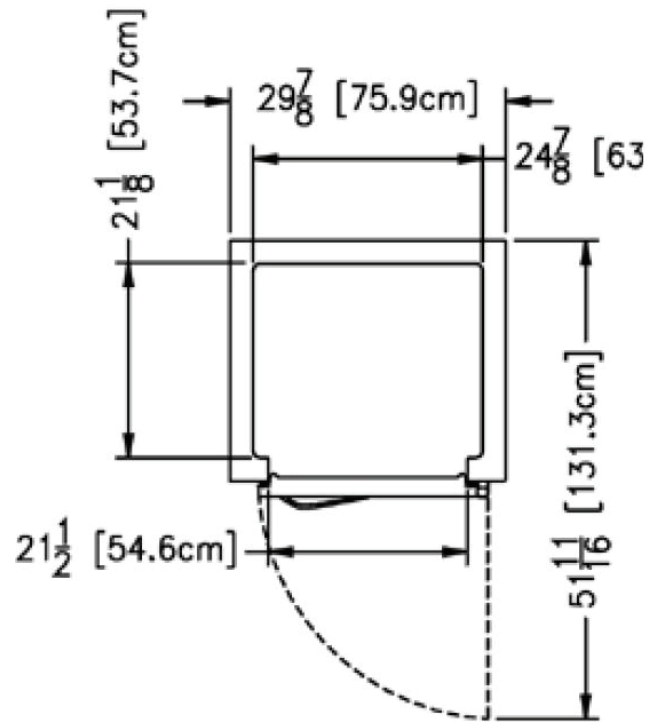
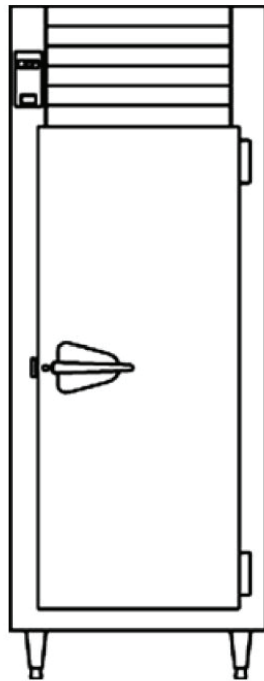

➤ CAD and/or Revit Files Available

<https://traulsen.klccad.com/>



### MODEL

ALT126WUT-HHS  
ALT126WUT-FHS

### EQUIPMENT SPECIFICATIONS

MODELS	ALT126WUT
<b>DIMENSIONAL DATA</b>	
Net capacity cu. ft.	17.67 (500.4 cu l)
Length - overall in.	29 7/8" (75.9 cm)
Depth - overall in.	29" (73.6 cm)
Depth - over body in.	26" (66 cm)
Depth - door open 90° in.	51 11/16" (131.3 cm)
Clear door width in.	21 1/2" (54.6 cm)
Clear half-door height in.	27 1/2" (69.9 cm)
Clear full-door height in.	57 5/8" (146.3 cm)
Height - overall on 6" legs <sup>3</sup>	83 1/4" (211.5 cm)
No. Standard Shelves	3
Shelf area sq. ft. <sup>1</sup>	10.46 (0.97 sq. m)
<b>ELECTRICAL DATA</b>	
Voltage   Plug	115/60/1   NEMA 5-20P
Full Load Amperes   MDEC <sup>4</sup>	8.7   5 kWh/Day
<b>REFRIGERATION DATA</b>	
Refrigerant	R-448A
Refrigerant Charge Amount oz.	12 (340.2 g)
BTU/HR   H.P. <sup>2</sup>	1890   1/2 HP
<b>SHIPPING DATA</b>	
Length - Crated in.	48" (121.9 cm)
Width - Crated in.	42" (106.7 cm)
Height - Crated in.	85" (215.9 cm)
Volume - Crated cu. ft.	99.17 (2808.2 cu l)
Weight - Crated lbs.	412 (186.9 kg)

**NOTES:** Figures in parentheses reflect metric equivalents.

1. Area of standard shelf compliment only, does not include storage area of additional shelves or available on cabinet bottom.
2. Based on a 90°F ambient & -20°F evaporator.
3. 12" Top clearance preferred for optimum performance and service access.
4. MDEC = Maximum Daily Energy Consumption

When ordering please specify: Voltage, Hinging, and Options.

Equipped with one NEMA 5-20P Plug



#### CONSTRUCTION, HARDWARE, INSULATION

Cabinet exterior front, one piece sides, louver assembly & door(s) are constructed of heavy gauge stainless steel. Cabinet interior & door liner(s) are also constructed of heavy gauge anodized aluminum. The exterior cabinet top, back & bottom are constructed of heavy gauge galvanized steel. A set of four (4) adjustable 6" high stainless steel legs are included.

Door(s) are equipped with a gasket-protecting metal door pan, removable plug cylinder locks & guaranteed for life cam-lift, gravity action, self-closing metal, glide hinges with stay open feature at 120 degrees. Hinges include a concealed switch to automatically activate the interior LED lighting. Guaranteed for life, work flow door handle(s) are mounted horizontally over recess in door which limits protrusion from door face into aiseways. Doors have seamless, polished metal corners.

Gasket profile & EZ-Clean material simplify cleaning & increase overall gasket life. Anti-condensate heaters are located behind the door opening. Both the cabinet & door is insulated with an average of 2" thick high density, non-CFC, foamed in place polyurethane.

#### SELF-CONTAINED REFRIGERATION SYSTEM

A top mounted, self-contained, balanced refrigeration system using environmentally friendly, non-flammable R-448A refrigerant is conveniently located behind the one piece louver assembly. It features a thermostatic expansion valve, air-cooled hermetic compressor, large, high humidity evaporator coil located outside the food zone & top mounted non-electric condensate evaporator. A 9' cord & plug is provided. Standard operating temperature is 0 to -5°F (all models are -10°F capable in up to 100°F ambient).

#### CONTROL

Traulsen's Smart Control features advanced control algorithms & sophisticated diagnostic capabilities to optimize performance. Utilizing Smart Sensors, it adapts the operation of the refrigeration system to a variety of environments & usage patterns. The Smart Control also offers a complete set of visual alarms designed to alert the user to critical events such as power outages or a prolonged door opening. In the event of an alarm, a dedicated Alarm LED will illuminate, informing the user of the critical event and duration.

#### INTERIOR

Standard interior arrangements include three (3) coated wire shelves per section, mounted on shelf pins. Shelves are full-width & do not have any large gaps between them requiring the use of "bridge" or "junior" shelves. Recommended load limit per shelf should not exceed 225 lbs. Interior arrangements are installed at the factory.

#### WARRANTY

Both a six year parts and labor warranty and a seven year compressor warranty (self-contained models only) are provided standard.

CONTINUED PRODUCT DEVELOPMENT MAY NECESSITATE SPECIFICATION CHANGES WITHOUT NOTICE.