

PBC-850-TS-CAB-1DR, 2-Rack 850 lbs Blast Chiller

BLAST CHILLER SPECIFICATIONS

The standard modular blast chiller solution includes the panel walk-in, evaporators, and condensing unit. The high-capacity unit is well suited to a high-volume professional kitchen workflow, making it possible to improve your kitchen efficiency and food quality while staying within HACCP guidelines.

Standard features include a NEW advanced touch screen controller with USB port, holding cycle (once your cycle is completed the unit automatically switches over to a cooler), a single point product core probe, and up to 99 customized recipe programs.

Touch screen controller



PBC850-TS
P/N 5979

EVAPORATOR OUTSIDE DIMENSIONS

(per evaporator coil)
28.8" W x 16.67" D x 72.08" H

OUTPUT CHILLING CAPACITY*

850 lbs within 90 minutes

OUTPUT THAWING CAPACITY*

0°F/38°F 170 lbs within 240 minutes
0°F/38°F 340 lbs within 480 minutes
0°F/38°F 510 lbs within 720 minutes

REFRIGERANT:

R448A

HEAT LOAD BTU/HR:

41,780/-10°F SST/+95°F ambient

ELECTRICAL SUPPLY:

1 PH/208-240 V/60 Hz

20 A circuit, # 12 wire required

STANDARD FEATURES

- New advanced 7" Gorilla glass touch screen controller with USB port on easy-to-use control panel
- Holding cycle: automatically switches over to holding mode after each cycle is completed
- One single point product core probe registers product temperatures
- Meets the demands of HACCP guidelines for proper food chilling
- Automatic air defrost
- Evaporator is enclosed in a frame and cabinet
- Programmable controller with up to 99 customized options
- Electric thawing heaters

WARRANTY

- Two years warranty on parts and labor
- Compressor warranty 3-5 years (parts only)

A COMPLETE SOLUTION

The package includes a PrepRite™ walk-in, perfectly designed to fit your blast chiller needs. The walk-in is available with 1 or 2 doors, external ramp, 8" deep interior ramp designed to accommodate two roll-in racks at 32" x 32" x 74" each and features our exclusive anti-bacterial Sanisteel interior metal finish.

It also includes an air cooled, remote, outdoor condensing unit as standard. Other condensing unit options, including indoor and water-cooled models are available on request.

Note: * Performance ratings for this unit are based on exterior dimensions of 64.5" W x 87" D x 88"H. Your performance results may vary based on the interior dimensions of your unit and the characteristics of the food being processed. Contact your regional sales person for more information.

Notes: The installation of the blast chiller and the installation of the remote condensing unit must be performed by a qualified professional. All specifications are subject to change without notice.

PBC-850-TS-CAB-1DR, 2-Rack 850 lbs Blast Chiller

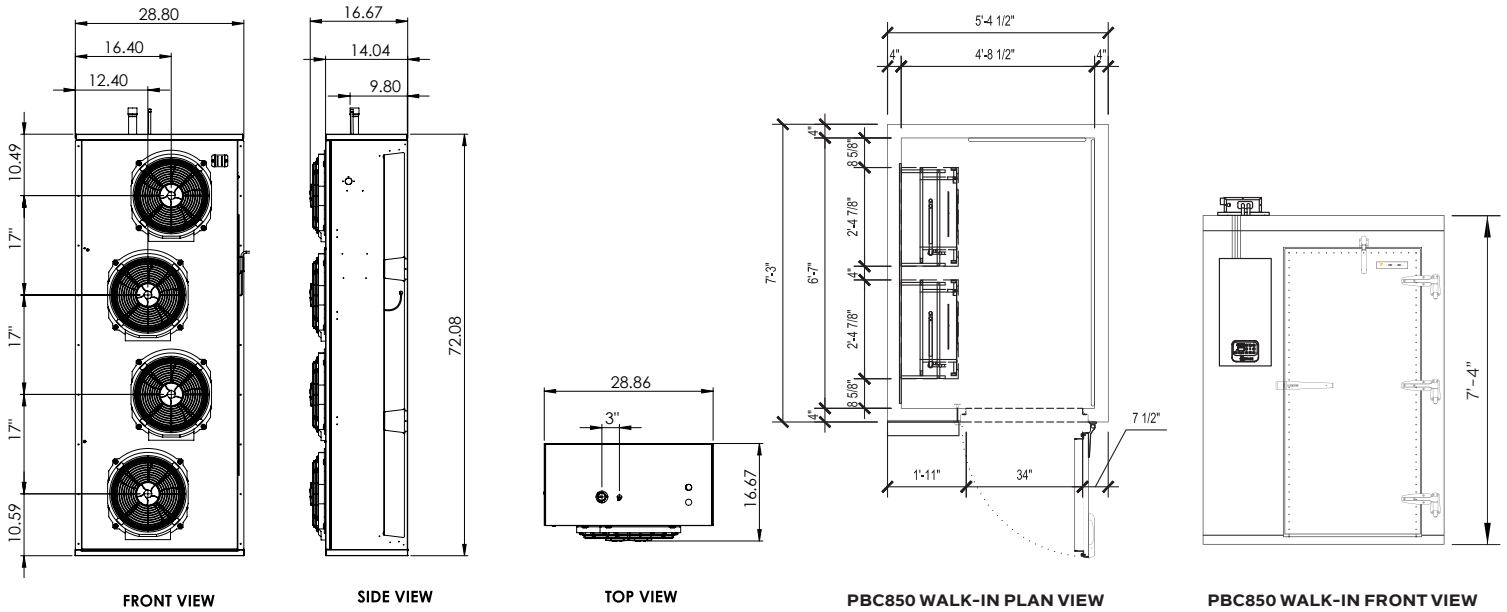

PBC850-TS includes two evaporator coils

EVAPORATOR MODEL	DIMENSIONS				
	OUTSIDE			SHIPPING	
	WIDTH	DEPTH	HEIGHT	DIMENSIONS	WEIGHT
PBC850-TS 5979	28.8"	16.67"	72.08"	81" x 41" x 19.5"	400 lbs

PBC850 WALK-IN DIMENSIONS (ins)		
WIDTH	DEPTH	HEIGHT
64.5	87	88

MAXIMUM LOAD PER CYCLE		ELECTRICAL DATA				REFRIGERATION DATA		
Chill	Volts	Hz	Phase	Amps	Circuit Amps	Refrigerant	Suction Line	Liquid Line
850 lbs	208-240	60	1	14.4	20	R448A	1.38	0.38

OUTDOOR REMOTE CONDENSING UNIT PBC-850-R448-CU-208/230 P/N 5965

All dimensions in inches

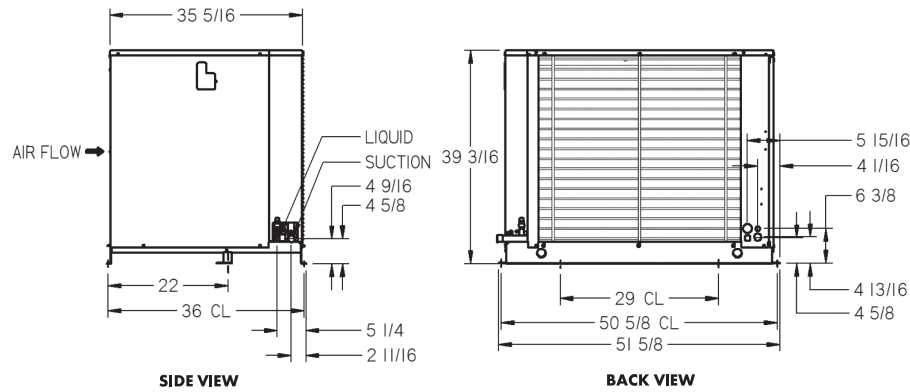

ELECTRICAL DATA – SUPPLY 3 PH/208-240 V/60 Hz											
Compressor(s)		Fan Motor(s)			Electric Ratings						
RLA	LRA	Qty.	Hp	FLA	Defrost Type	High or Low Amps	Contactors	MCA	MOPD	Evap. Fan Amps	Defrost Heater Amps
27.6	161	1	1/3	2.7	Air Defrost	High Amps	1	75	80	20	60

UNIT SPECIFICATIONS									
Refrigerant	Connections (ins)		Receiver 90% Full (lbs)		Fan Blade(s) Dia. (ins)	Sound Data (dB)	Approx. Net Weight (lbs)	Shipping Weight (lbs)	Shipping Dims. (ins) L x W x H
	Liquid Line	Suction	Standard	Oversized					
R448A	0.5	1.125	28	52	22	81	805	992	36.75 x 51.75 x 39.25

Notes: The installation of the blast chiller and the installation of the remote condensing unit must be performed by a qualified professional. All specifications are subject to change without notice



CROWNTONKA | ICS | LOTEMP DOORS | PREPRITE | THERMALRITE

Proud to be family-owned.

