

# HSM Series

## Heated Shelf Merchandiser



### HSM-36/3S/T & HSM-36/5S/T

Featuring exclusive Halo Heat® technology, Alto-Shaam heated shelf merchandisers provide precise, top and bottom heat for the highest quality prepared food- and longer hold times.

Hold a variety of grab-and-go products, including rotisserie chickens, pizza, sandwiches, and more. Drive foodservice profits with hot, ready-to-eat meals. Convenient, fresh meals are displayed in an aesthetically pleasing, customizable merchandiser.

**Experience better quality food** with gentle, even and precise Halo Heat® fanless technology to keep food from drying out.

**Flexibility to control individual shelf temperatures** allows you to hold a variety of products at the proper temperature.

**Boost impulse sales** with LED-lighted shelves, customized branding, backlit interchangeable graphics, pricing rails and window sides.

**Simple operation and easy cleaning** keeps delis and grab-and-go areas operating smoothly.

**Easy-to-load shelves** – pass-through option available for added convenience.

**Made in the USA** with a commitment to quality. Alto-Shaam is ISO 9001:2015-certified.

#### Standard Features

- Adjustable thermostat per shelf with a heat-on indicator light
- Latched access panel on the front of the merchandiser
- Four casters



CAPACITY

**8** HSM-36: Three [3] 32-7/8" [835mm] width shelves, eight [8] chicken boats with dome cover per shelf,

**24** or twenty-four [24] individually wrapped sandwiches.



HSM-36/5S/T



HSM-36/3S/T

#### Configurations (select one)

##### Model

- HSM-36/3S/T
- HSM-36/5S/T

##### Electrical

- 208–240V, 1PH

##### Door Options

- None [reach-in models only]
- Rear slide [pass-through models only]
- Rear swing [pass-through models only]
- Front swing [reach-in and pass-through models]

##### Legs or Casters (floor standing)

- 4" [102mm] -6" [153mm] adjustable legs [5025454]
- 3" [76mm] casters [Standard]

##### Legs or Display Base (countertop)

- 4" [102mm] -6" [153mm] adjustable legs: [Standard] [5026182]
- HSM-36/3S-CT Display Base, with casters [5026176]
- HSM-36/3S-CT Display Base, with legs [5026182]

#### Accessories (select all that apply)

qty

Note: Unit ships without graphics unless selected

- Signage panel, POP Display
- Signage panel, shelf – Rotisserie Chicken
- Signage panel, shelf – Hot Sandwiches
- Signage panel, shelf – Barbecue Ribs
- Signage panel, shelf – Hot & Tasty
- Signage panel, shelf – Grab & Go
- Signage panel, shelf – Hot & Fresh
- Shelf insert for magnetic signage panels, HSM-24/5S [1027304]. Magnetic signage panels to be provided by customer.
- Shelf insert for magnetic signage panels, HSM-36/5S [1027305]. Magnetic signage panels to be provided by customer.
- Shelf insert for magnetic signage panels, HSM-48/5S [1027306]. Magnetic signage panels to be provided by customer.

# HSM Series



HSM-36/5S/T

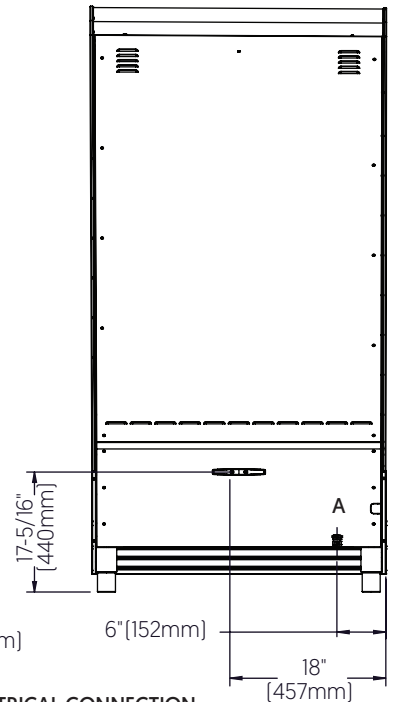
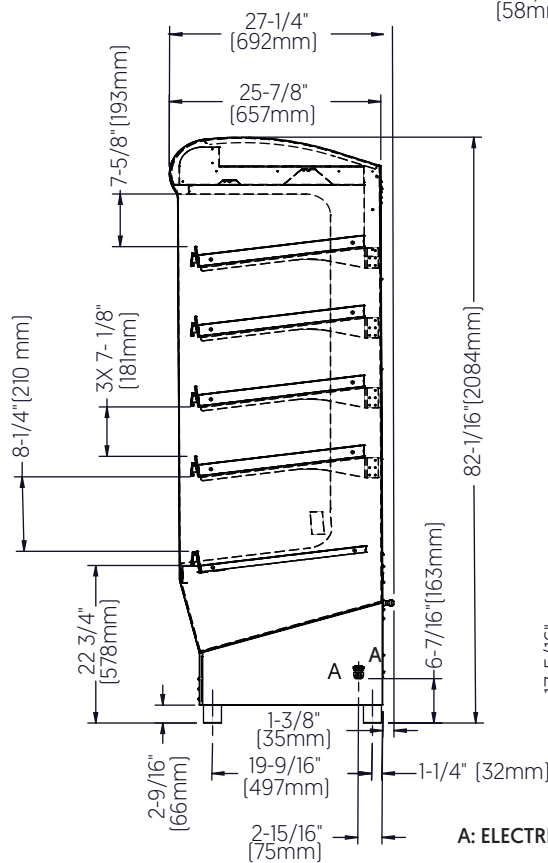
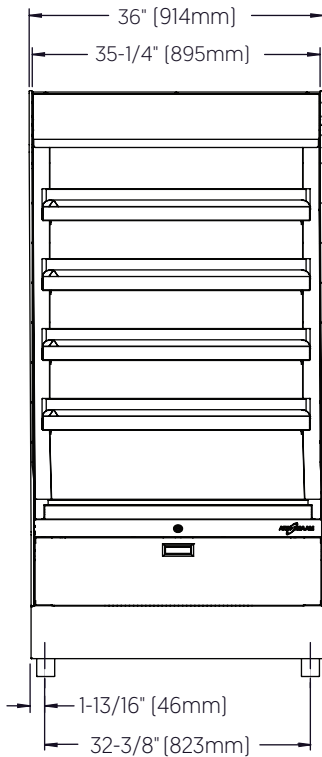
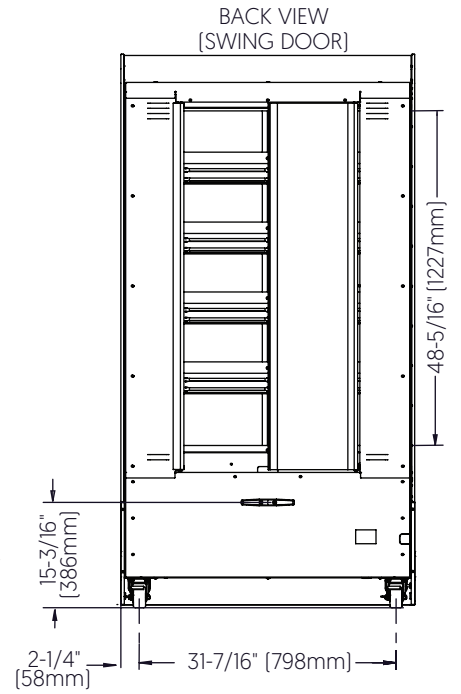
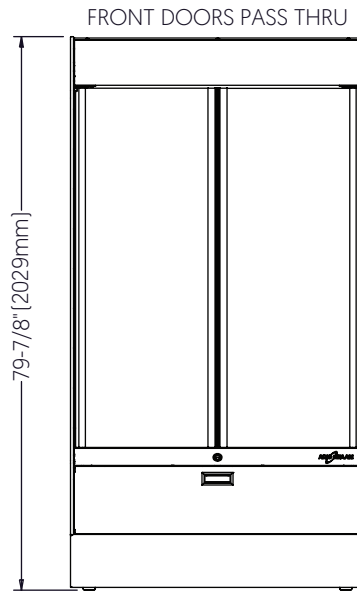
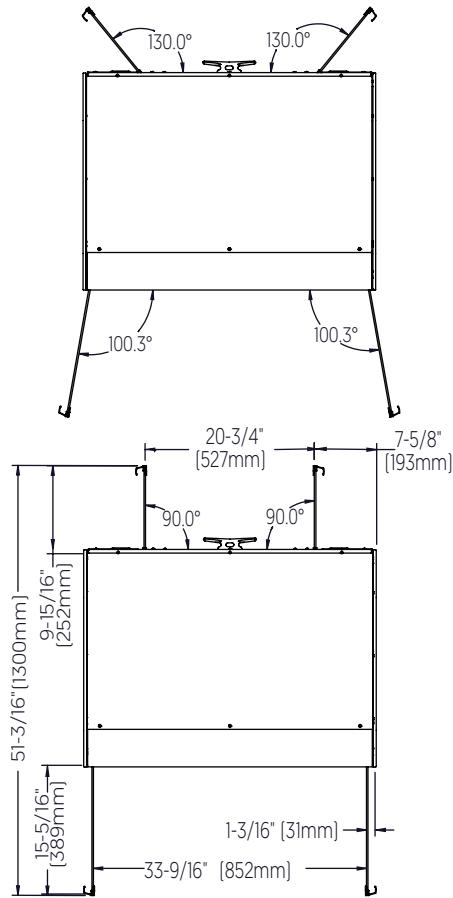

# HSM Series



HSM-36/3S/T

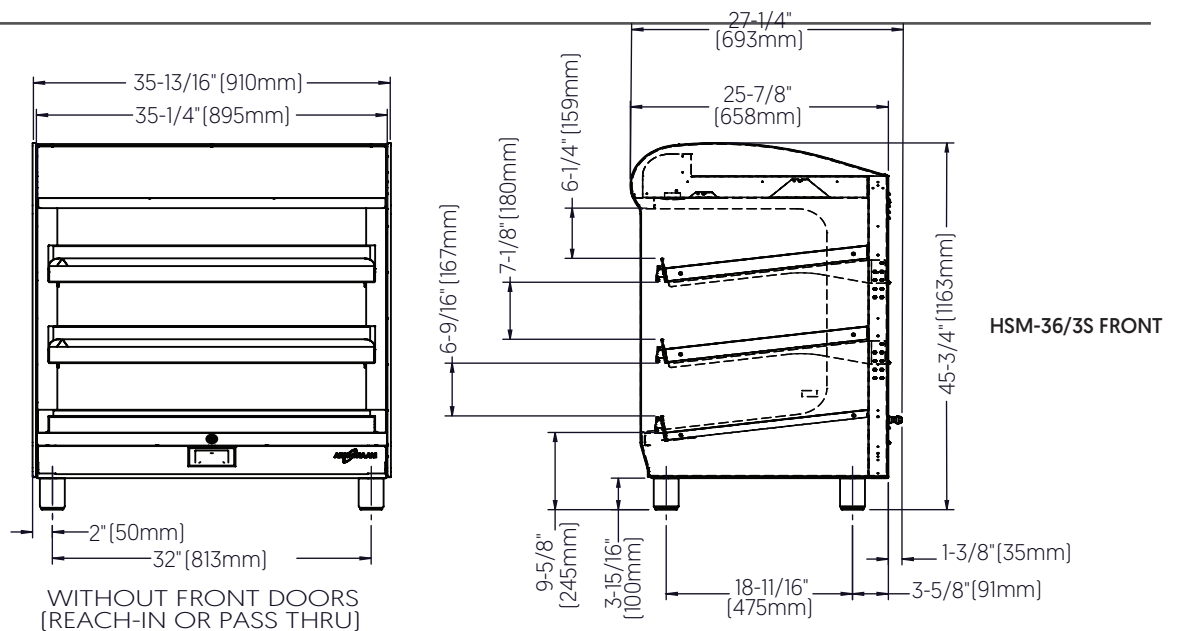
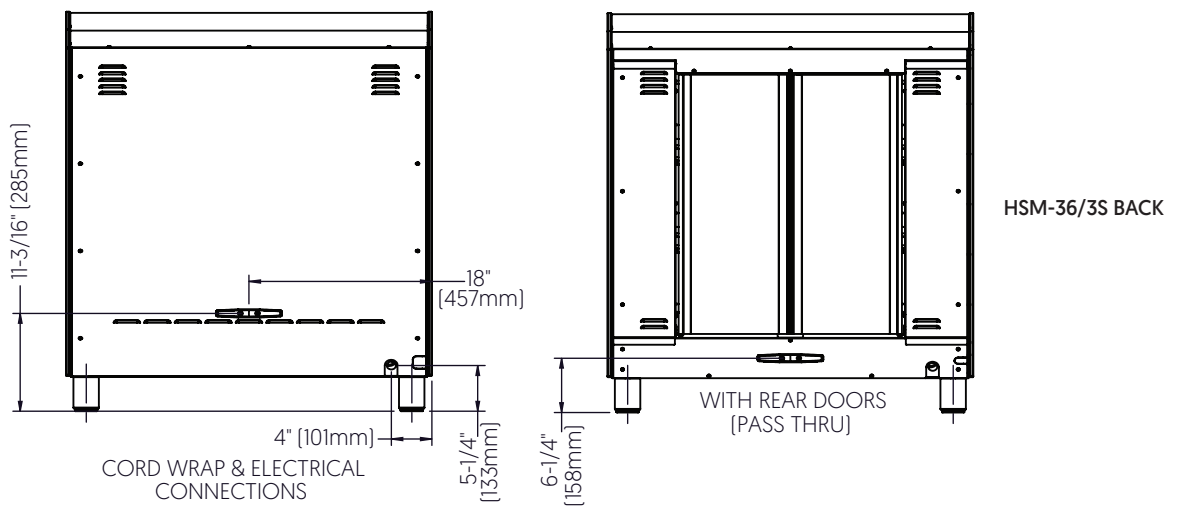
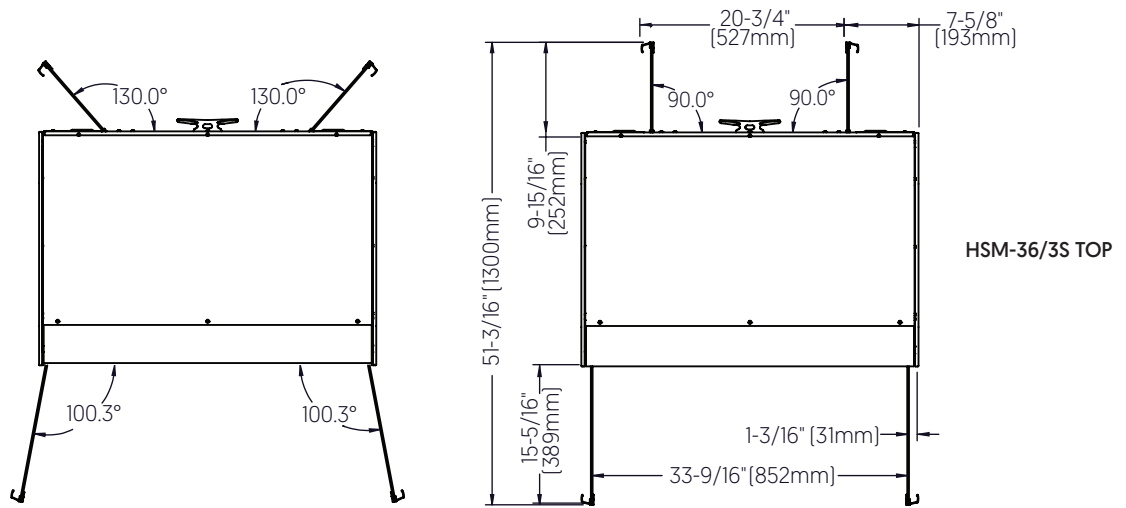

# HSM Series



## HSM-36/3S/T & HSM-36/5S/T

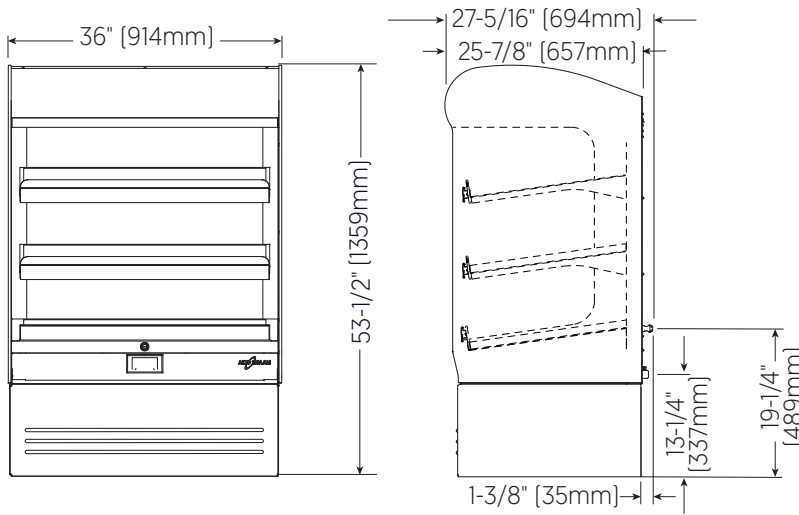

HSM-36/3S/T  
SHOWN WITH  
DISPLAY BASE

Model	Exterior (H x W x D)	Net Weight
HSM-36/3S/T	45-3/4" x 35-13/16" x 27-1/4" [1363mm x 910mm x 693mm]	311 lb [141 kg]
HSM-36/5S/T	82-1/16" x 36" x 27-1/4" [2084mm x 914mm x 694mm]	563 lb [255 kg]
Ship Dimensions (L x W x H)*		Ship Weight*
HSM-36/3S/T	56" x 45" x 64-1/2" [1422mm x 1143mm x 1638mm]	652 lb [296 kg]
HSM-36/5S/T	56" x 63" x 89" [1422mm x 1600mm x 2261mm]	772 lb [350 kg]

\*Domestic ground shipping information. Contact factory for export weight and dimensions.



**CLEARANCE**

### Rear: 4" (102mm)

Recommended: 18" [457mm] for service access. Charges in connection with inadequate service access is not covered under warranty.



**CHECK FIRST**

- Merchandiser must be installed level.
- Merchandiser must not be installed in any area where it may be affected by steam, grease, dripping water, high temperatures, or any other severely adverse conditions.



**ELECTRIC**

HSM-36/3S	V	Ph	Hz	Awg	IEC	A	Breaker (A)	kW	Plug Configuration	Certification
208-240V	208	1	60	10	—	8.8	15 UL   20 CSA	1.8	NEMA 6-15A	
	240	1	60	10	—	10.0	15 UL   20 CSA	2.4	NEMA 6-15A	

Electrical connections must meet all applicable federal, state, and local codes. Dedicated circuit required.

HSM-36/5S	V	Ph	Hz	Awg	IEC	A	Breaker (A)	kW	Plug Configuration	Certification
208-240V	208	1	60	10	—	14.6	20 UL   30 CSA	3.0	NEMA 6-20A	
	240	1	60	10	—	16.7	20 UL   30 CSA	4.0	NEMA 6-20A	

Electrical connections must meet all applicable federal, state, and local codes. Dedicated circuit required.

## CONTACT US

W164 N9221 Water Street | Menomonee Falls, Wisconsin 53051 | U.S.A.  
Phone: 262.251.3800 | 800.558.8744 U.S.A./Canada | Fax: 262.251.7067 | [alto-shaam.com](http://alto-shaam.com)