

# DESIGNER LINE PASS THRU FREEZER (0°)

**Model: D2FENPTHD**

## 2-Section Extra-Wide Pass-Thru Freezer with Half Doors

**D2FENPTHD** - Stainless steel front, aluminum end panels and interior  
**D2FENSAPTHD** - Stainless steel exterior, aluminum interior  
**D2FENSSPTHD** - Stainless steel exterior and interior  
 Designed to maintain NSF-7 temperatures in 100°F ambient.



## Options and Accessories

(upcharge and lead times may apply)

Additional epoxy coated steel shelves	Custom laminates
Chrome or stainless steel shelves	Special electrical req. (consult factory)
Casters	<b>Correctional Facility Options</b>
Rehinging of doors (consult factory)	<ul style="list-style-type: none"> <li>One way security screws</li> </ul>
Half doors	<ul style="list-style-type: none"> <li>Locking hasp (lock not included)</li> </ul>
Pan slide assemblies	<ul style="list-style-type: none"> <li>Stainless steel mesh cover</li> <li>Coverless hinges</li> </ul>

Consult factory for other model configurations, options and accessories.

**Continental**<sup>®</sup>  
Refrigerator



Project Name:

Model Specified:

Location:

Item No:

Quantity:

AIA #:

SIS #:

## Standard Model Features

### REFRIGERATION SYSTEM

Self contained, performance rated "plug" refrigeration system

Natural, environmentally safe, high efficiency R-290 refrigerant<sup>1</sup>

Refrigeration system is readily accessible on top of cabinet, separate from the "food zone"

Automatic, hot gas condensate evaporator

Expansion valve system

Standard operating temperature is 0 to -5°F and can be adjusted to operate as low as -10°F in a 90°F ambient.

### CABINET ARCHITECTURE

3" non-CFC polyurethane foam insulation

Smooth, polished chrome workflow door handle

Cam action, lift off hinges

Self-closing door

Magnetic snap-in Santoprene™ door gasket

Cylinder lock in door

Heavy duty pilaster strips

Heavy duty, epoxy coated steel shelves

Adjustable 6" stainless steel legs

### MODEL FEATURES

LED interior lighting

Electronic controller with digital display & hi-low alarm

Automatic electric defrost

Top and side air distribution ducts

Cabinet upper side panels and refrigeration "plug" system can be removed and reinstalled at job site

<sup>1</sup> R-290 refrigerant meets all federal and state regulatory requirements.

APPROVAL:

# Model Specifications

## DIMENSIONAL DATA

Net Capacity (cubic feet)	52 (1472 cu l)
Width, Overall (inches)	57 (1448 mm)
Depth, Overall (inches) (including handles)	35 <sup>3</sup> / <sub>8</sub> (899 mm)
Depth (inches) (less doors)	32 (813 mm)
Depth (inches) (doors open 90°)	58 (1473 mm)
Clear Door Width (inches)	21 <sup>7</sup> / <sub>8</sub> (556 mm)
Clear Door Height (inches)	58 <sup>5</sup> / <sub>8</sub> (1489 mm)
Height, Overall (inches) (including 6" legs)	83 <sup>1</sup> / <sub>4</sub> (2115 mm)
Number of Doors	2
Number of Shelves	6
Shelf Area (square feet)	40.8 (3.8 sq m)
Tray Slide Capacity (per section)	24

## REFRIGERANT DATA

Condensing Unit Size (H.P.)	1
Capacity (BTU per hour)*	2470

## ELECTRICAL DATA

Voltage (International)	115/60/1 (220/50/1)
Feed Wires (including ground)	3
Total Amps (International)	9.7 (6.2)
Defrost Amps (International)	5.2 (2.6)
10 ft. Cord/Plug [attached] (International)	Yes (No)

## SHIPPING DATA

Height - Crated (inches)	85 <sup>1</sup> / <sub>2</sub> (2172 mm)
Width - Crated (inches)	64 (1626 mm)
Depth - Crated (inches)	42 (1067 mm)
Volume - Crated (cubic feet)	133 (3766 cu l)
Weight Std - Crated (pounds)	575 (261 kg)
Weight SS - Crated (pounds)	605 (274 kg)

\* Rating @ +25°F evaporator, 90°F ambient  
Figures in parentheses reflect metric equivalents rounded to the nearest whole unit.



Equipped with one NEMA-5-15P Plug  
(varies by country)

# Model Plan Views

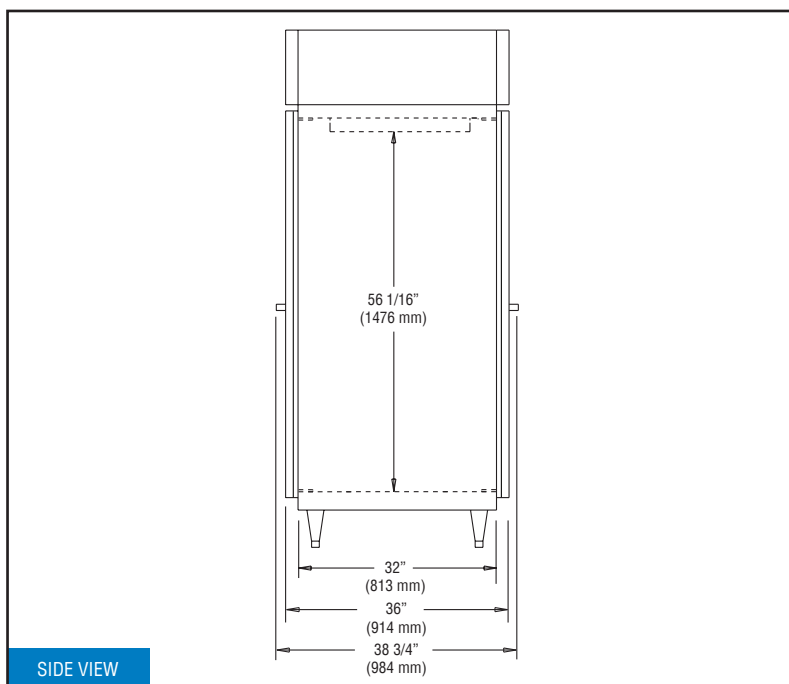
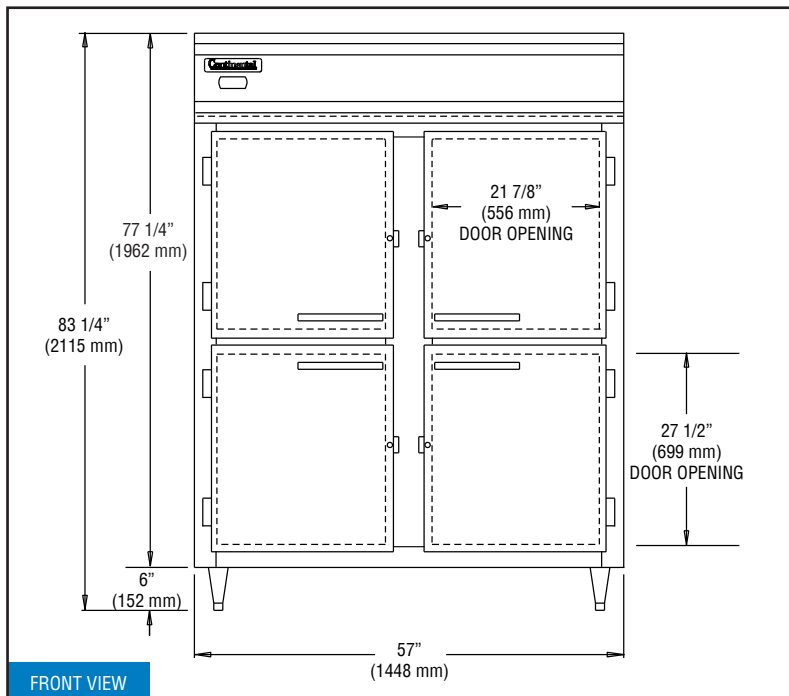

**Continental**  
Refrigerator

Toll-Free: 800-523-7138  
Phone: 215-244-1400  
Fax: 215-244-9579

539 Dunksferry Road  
Bensalem, PA 19020  
[www.continentalrefrigerator.com](http://www.continentalrefrigerator.com)

Due to our continued efforts in developing innovative products, specifications subject to change without notice.



PROUDLY  
DESIGNED & ASSEMBLED  
IN THE U.S.A.

**Intertek**

© Copyright 2021. Continental Refrigerator.  
A Division of National Refrigeration & Air Conditioning Products, Inc.

REVISED: 2/13/24