



Project _____

AIA # _____ SIS # _____

Item # _____ Quantity _____ C.S.I. Section 114000

A-Series

W-Width Convertible Reach-In Model
32" Deep, Self-Contained



STANDARD PRODUCT FEATURES

- Flip Switch to Convert the Cabinet from Refrigerator to Freezer or Freezer to Refrigerator
- Traulsen's Smart Control with LED Display
- Stainless Steel Exterior/ Anodized Aluminum Interior
- Balanced, Self-Contained Refrigeration System Using R-290
- Full or Half-Height Stainless Steel Door(s) with Lock(s)
- Anti-Condensate Door Perimeter Heater
- Self-Closing Door with Stay Open Feature at 120 Degrees
- Standard Door Hinging: 132W = Right (other hings available)
- Automatically Activated LED Lights
- Stainless Steel Breaker Caps
- Three Adjustable, Coated Wire Shelves Per Section, Supported on Shelf Pins (factory installed)
- Automatic Non-Electric Condensate Evaporator
- Magnetic Snap-In EZ-Clean Door Gasket
- Gasket-Protecting Raised Door Liner
- Controllable Anti-Condensate Evaporator
- Thermostatic Expansion Valve Metering Device
- Stainless Steel One-Piece Louver Assembly
- 9' Cord & Plug Attached
- Set of (4) 6" High Adjustable Stainless Steel Legs



Intertek



This unit is listed to the applicable UL, CSA and NSF Standards by an approved NRTL. Consult the factory or unit's data plate for approval information.

AVAILABLE CONFIGURATIONS

A-Series Models

ACV132WUT-FHS
ACV132WUT-HHS

Door(s)

Full Height Solid
Half Height Solid

ACCESSORIES & OPTIONS

- Stainless Steel Finished Back with Rear Louvers
- Heat Shield
- #1 Type Trayslides to Accommodate either (1) 18" x 26" or (2) 14" x 18" Sheet Pans
- #4 Type Trayslides to Accommodate 18 to 19 Levels for 18" x 26" Pans
- Universal Type Trayslides to Accommodate Either (1) 18" x 26", (2) 14" x 18" Sheet Pans, or (2) 12" x 20" Steam Table Pans
- Additional Coated Wire or Optional Stainless Steel Shelves
- EZ-Change Interiors (#1, universals, universal heavy duty trayslides & shelves)
- EZ-Open Foot Pedal (full-height doors only)
- Locking Hasps (padlocks supplied by others)
- Kool Klad Exterior Laminate Decor
- Set of (4) 6" Stainless Steel Flanged Legs
- Set of (4) 4 1/8" or 6" High Casters in Lieu of Legs
- Other Support Options: 4 1/2" High Base or 6" High Kickplate (for use with standard legs)
- Prison/Correctional Facilities Options

- GUARANTEED FOR LIFE CAM-LIFT HINGES
- GUARANTEED FOR LIFE HORIZONTAL WORK FLOW DOOR HANDLES (SOLID DOORS ONLY)

Approved by _____ Date _____ Approved by _____ Date _____

MODEL

ACV132WUT-HHS

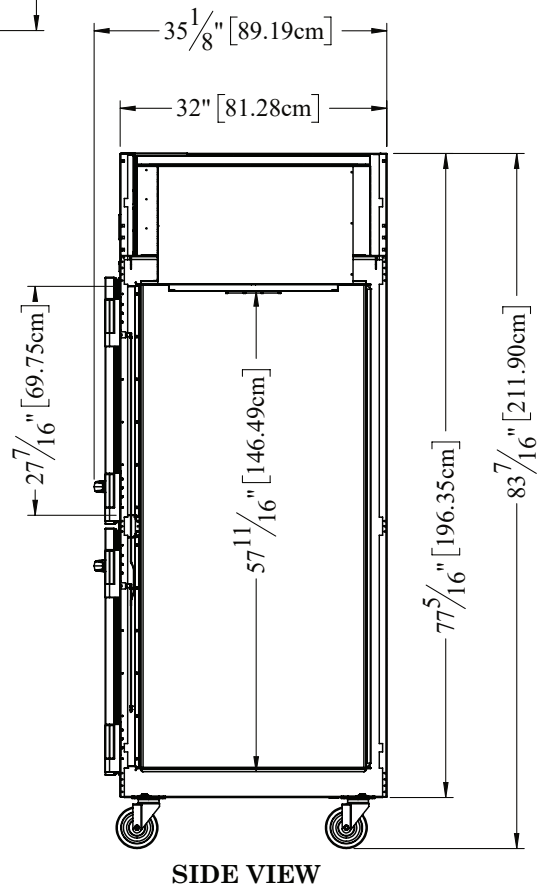
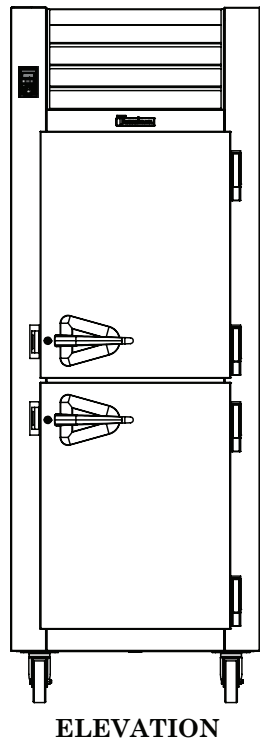
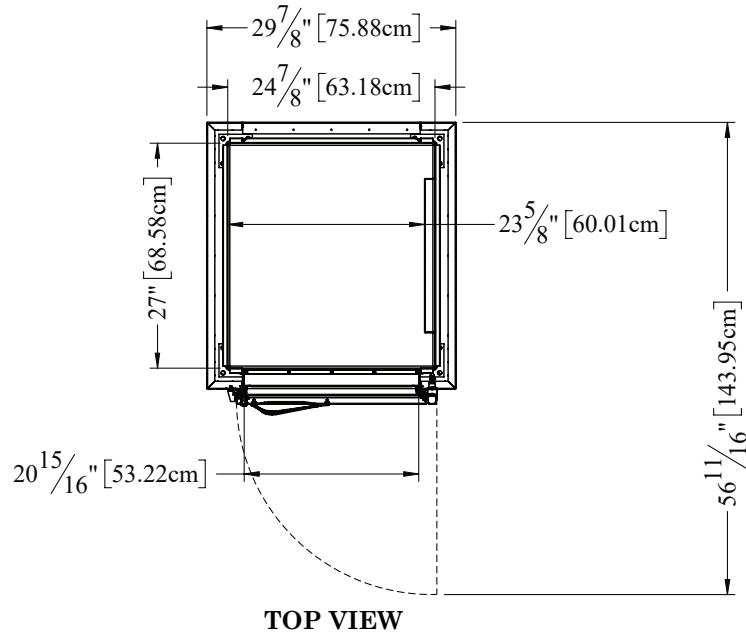

> CAD and/or Revit Files Available

<https://traulsen.klccad.com/>



A-Series

W-Width Convertible Reach-In Model
32" Deep, Self-Contained

MODEL

ACV132WUT-FHS

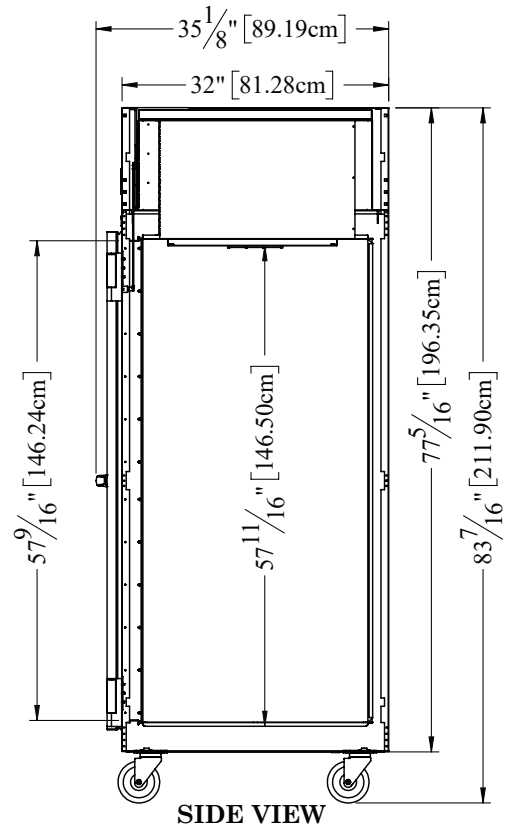
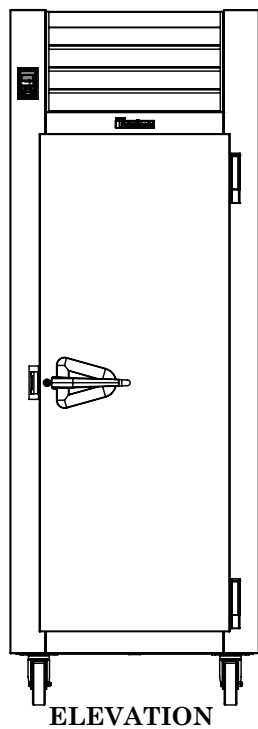
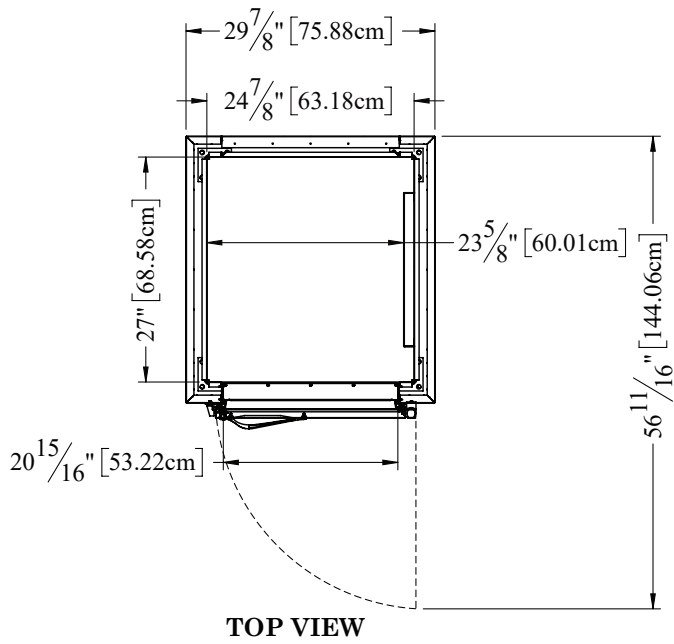

> CAD and/or Revit Files Available

<https://traulsen.kclcad.com/>



MODEL

ACV132WUT-HHS
ACV132WUT-FHS

EQUIPMENT SPECIFICATIONS

MODELS	ACV132WUT
DIMENSIONAL DATA	
Net capacity cu. ft.	23.43 (663.5 cu l)
Length - overall in.	29 7/8" (75.9 cm)
Depth - overall in.	35 1/8" (89.2 cm)
Depth - over body in.	32" (81.3 cm)
Depth - door open 90° in.	56 11/16" (144 cm)
Clear door width in.	20 15/16" (53.2 cm)
Clear half-door height in.	27 7/16" (69.8 cm)
Clear full-door height in.	57 9/16" (146.3 cm)
Height - overall on 6" legs ²	83 7/16" (211.9 cm)
Shelf area sq. ft.	12.64 (1.17 sq m)
ELECTRICAL DATA	
Voltage Plug	115/60/1 NEMA 5-15P
Full Load Amperes MDEC ³	2.4 6.21 kWh/Day
REFRIGERATION DATA	
Refrigerant	R-290
Refrigerant Charge Amount oz.	5.29 (150 g)
BTU/HR H.P. ¹	2580 3/4 HP
SHIPPING DATA	
Length - Crated in.	48" (121.9 cm)
Width - Crated in.	42" (106.7 cm)
Height - Crated in.	85" (216 cm)
Volume - Crated cu. ft.	99.17 (2808.2 cu l)
Weight - Crated lbs.	450 (204 kg)

CONSTRUCTION, HARDWARE, INSULATION

Cabinet exterior front, one piece sides, louver assembly & door is constructed of heavy gauge anodized aluminum. Cabinet interior & door liner is also constructed of anodized aluminum. The exterior cabinet top, back & bottom are constructed of heavy gauge galvanized steel. A set of four (4) adjustable 6" high stainless steel legs are included.

Door is equipped with removable plug cylinder locks & guaranteed for life cam-lift, gravity action, self-closing metal, glide hinges with stay open feature at 120 degrees. Hinges include a switch to automatically activate the interior LED lighting. Guaranteed for life, work flow door handle is mounted horizontally over recess in door which limits protrusion from door face into aiseways.

Gasket profile & EZ-Clean material simplify cleaning & increase overall gasket life. Anti-condensate heaters are located behind the door opening. Both the cabinet & door is insulated with high density, non-CFC, foamed in place polyurethane.

SELF-CONTAINED REFRIGERATION SYSTEM

A top mounted, self-contained, balanced refrigeration system using R-290 refrigerant is conveniently located behind the one piece louver assembly. It features a high humidity evaporator coil located outside the food zone, top mounted non-electric condensate evaporator, & an automatic preset time activated electric defrost. A face mounted key switch is provided to convert operation from refrigerator mode. Standard operating temperature in freezer mode is -10 to 0°F. Operating temperature in refrigerator mode is 34-38°F. Operating temperatures are not adjustable.

CONTROL

Traulsen's Smart Control features advanced control algorithms & sophisticated diagnostic capabilities to optimize performance. Utilizing Smart Sensors, it adapts the operation of the refrigeration system to a variety of environments & usage patterns. The Smart Control also offers a complete set of visual alarms designed to alert the user to critical events such as power outages or a prolonged door opening. In the event of an alarm, a dedicated Alarm LED will illuminate, informing the user of the critical event and duration.

INTERIOR

Standard interior arrangements include three (3) coated wire shelves per section, mounted on shelf pins. Shelves are full-width & do not have any large gaps between them requiring the use of "bridge" or "junior" shelves. Recommended load limit per shelf should not exceed 225 lbs. Optional trayslides may be purchased in combination with, or in lieu of these. Interior arrangements are factory-installed & EZ-Change interior slides (only) are field installed.

WARRANTY

Both a six year parts and labor warranty and a seven year compressor warranty (self-contained models only) are provided standard.

NOTES: Figures in parentheses reflect metric equivalents.

1. Based on a 90°F ambient and -10°F evaporator.
2. 12" Top clearance preferred for optimum performance & service access.
3. MDEC = Maximum Daily Energy Consumption

When ordering please specify: Voltage, Hinging, and Options.

Equipped with one NEMA 5-15P Plug

