

"UBDB-45-IC" UNDERBAR DRAINBOARDS

45 ° Inside Corner, Mounts To Other Underbar Equipment

FEATURES:

- 18GA Stainless Steel Construction
- Type 300 Stainless Steel With #4 Polish, Satin Finish
- Standard Pre-Drilled Holes On Sides For Attaching Adjacent Units Together
- Inside Corner 45 ° Angle
- Legs Not Included

SPECIFICATIONS:

- Top: 18GA Type 300 Stainless Steel
- Front Apron: 18GA Type 300 Stainless Steel
- Backsplash: 18GA Type 300 Stainless Steel
- Sides: 18GA Type 300 Stainless Steel
- Bolt On 1-5/8" Stainless Steel Legs For Fast Installation
- 1-1/4" Front To Back Bracing
- Z-Clip To Mount To Wall
- Bolt To Adjacent Underbar Piece
- 1-3/8" Drain
- 1" MPT 1-1/2" Long Drain Connection

CERTIFICATIONS:



UBDB-2112-45-IC

"UBDB-45-IC" UNDERBAR DRAINBOARDS

MODEL	SIZE (LXWXH)	WEIGHT (LBS)
UBDB-1812-45-IC	12"x18"x17"	22
UBDB-2112-45-IC	12"x21"x17"	24

ALL DIMENSIONS ARE TYPICAL. TOLERANCE +/- .500". JOHN BOOS & CO. RESERVES THE RIGHT TO CHANGE SPECIFICATIONS WITHOUT NOTICE.

DETAILED SPECIFICATIONS

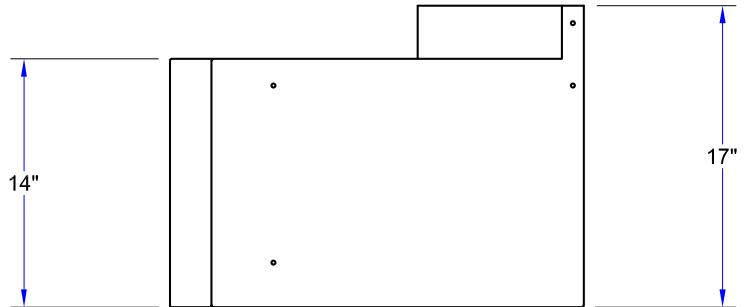
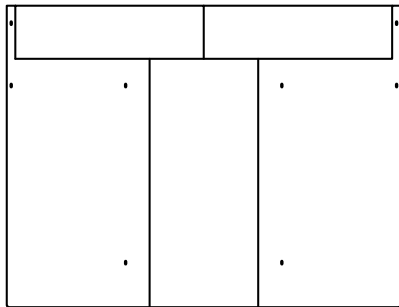
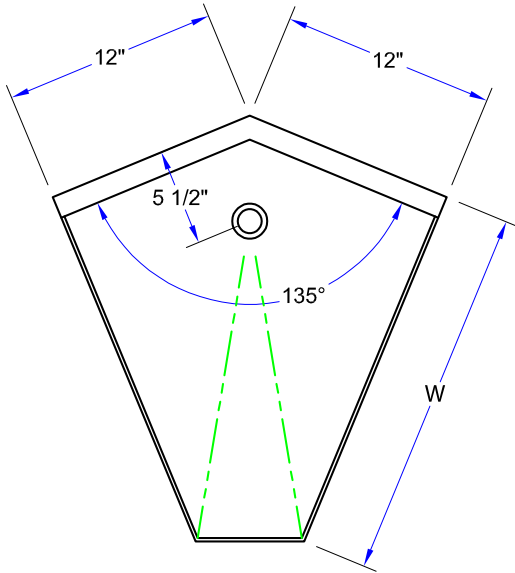

"UBDB-45-IC" UNDERBAR DRAINBOARDS

MODEL	SIZE (LXWXH)	WEIGHT (LBS)
UBDB-1812-45-IC	12"x18"x17"	22
UBDB-2112-45-IC	12"x21"x17"	24

ALL DIMENSIONS ARE TYPICAL. TOLERANCE +/- .500". JOHN BOOS & CO. RESERVES THE RIGHT TO CHANGE SPECIFICATIONS WITHOUT NOTICE.