

# Specification Sheet

## Short Form Specifications

Blendport worktables, Budget series model \_\_\_\_\_ . Top constructed of heavy gauge, type 430 stainless steel with 1½" roll on front and rear, and sides turned down 90°. Undershef is adjustable and constructed of heavy gauge galvanized. Top reinforced with welded hat channels, and sound deadened. Constructed with uni-lok® patented gusset system with the gussets recessed into the hat channels to reduce lateral movement. Legs are 1½" O.D. galvanized tubing with galvanized gussets, and 1" hi-impact plastic bullet feet.

Item No.:	_____
Project No.:	_____
S.I.S. No.:	_____

## Worktables with Flat Top and Galvanized Base with Adjustable Undershelf—Budget Series

### MODELS:

- |                                    |                                    |                                    |
|------------------------------------|------------------------------------|------------------------------------|
| <input type="checkbox"/> BPT-2424B | <input type="checkbox"/> BPT-2484B | <input type="checkbox"/> BPT-3060B |
| <input type="checkbox"/> BPT-2430B | <input type="checkbox"/> BPT-2496B | <input type="checkbox"/> BPT-3072B |
| <input type="checkbox"/> BPT-2436B | <input type="checkbox"/> BPT-3024B | <input type="checkbox"/> BPT-3084B |
| <input type="checkbox"/> BPT-2448B | <input type="checkbox"/> BPT-3030B | <input type="checkbox"/> BPT-3096B |
| <input type="checkbox"/> BPT-2460B | <input type="checkbox"/> BPT-3036B |                                    |
| <input type="checkbox"/> BPT-2472B | <input type="checkbox"/> BPT-3048B |                                    |



*worktable with flat top and undershef*

### Tabletop

- Patented uni-lok® gusset system (patent #5,165,349): gussets are recessed into hat channel, reducing lateral movement.
- Top reinforced with welded-on hat channel.
- Sound-deadened between top and channels.
- 1½" (38mm)-diameter 180° rolled edges on front and rear. Ends are turned down 90° providing for flush installations when required.
- Heavy gauge type 430 polished stainless steel.

### Adjustable Undershelf

- Heavy gauge, galvanized.
- Gusset welded to each corner.

### Legs—1½" (41mm)-diameter

- Tables 96" (2438mm) and longer come with six legs or more.
- Heavy gauge galvanized steel.
- 1" (25mm) adjustable hi-impact plastic feet\*.

\* Optional casters available. Consult factory.

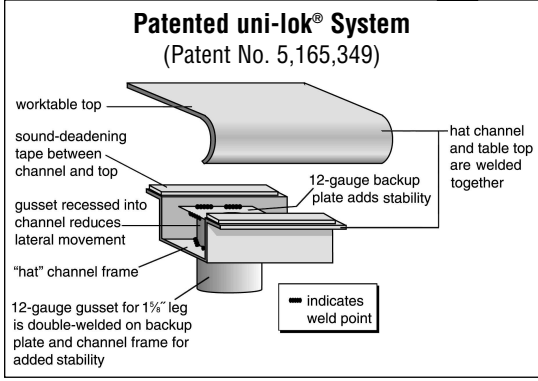

Item No.: \_\_\_\_\_  
 Project No.: \_\_\_\_\_  
 S.I.S. No.: \_\_\_\_\_

## Worktables with Flat Top and Galvanized Base with Adjustable Undershelf—Budget Series

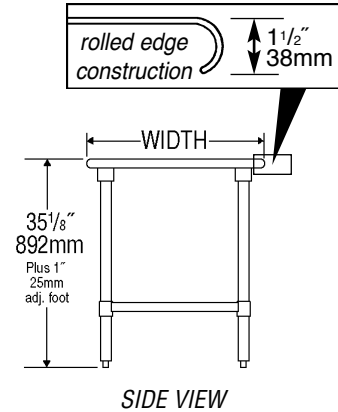
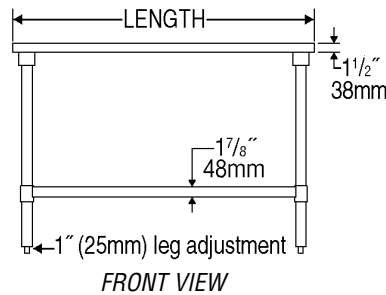
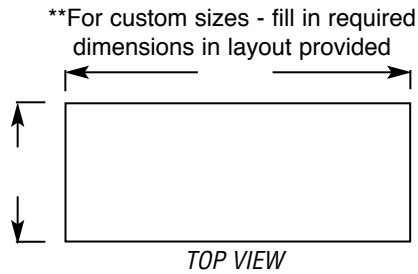

model #	# of legs	width		length		weight	
		in.	mm	in.	mm	lbs.	kg
<b>BPT-2424B</b>	4	24"	610	24"	610	40	18.1
<b>BPT-2430B</b>	4	24"	610	30"	762	45	20.4
<b>BPT-2436B</b>	4	24"	610	36"	914	50	22.7
<b>BPT-2448B</b>	4	24"	610	48"	1219	60	27.2
<b>BPT-2460B</b>	4	24"	610	60"	1524	70	31.8
<b>BPT-2472B</b>	4	24"	610	72"	1829	80	36.3
<b>BPT-2484B</b>	4	24"	610	84"	2134	90	40.8
<b>BPT-2496B</b>	6	24"	610	96"	2438	100	45.4
<b>BPT-3024B</b>	4	30"	762	24"	610	45	20.4
<b>BPT-3030B</b>	4	30"	762	30"	762	46	20.9
<b>BPT-3036B</b>	4	30"	762	36"	914	52	23.6
<b>BPT-3048B</b>	4	30"	762	48"	1219	64	29.0
<b>BPT-3060B</b>	4	30"	762	60"	1524	76	34.5
<b>BPT-3072B</b>	4	30"	762	72"	1829	84	38.1
<b>BPT-3084B</b>	4	30"	762	84"	2134	96	43.6
<b>BPT-3096B</b>	6	30"	762	96"	2438	108	49.0

**BlendPort®**

An Eagle Group Company

100 Industrial Boulevard, Clayton, DE 19938-8903 USA

Phone: 800-441-8440 • Fax: 302-653-2065

 Printed in U.S.A.  
 ©2020 by Eagle Group

Rev. 05/20

Although every attempt has been made to ensure the accuracy of the information provided, we cannot be held responsible for typographical or printing errors. Information and specifications are subject to change without notice. Please confirm at time of order.