

Glass Frosters / Chillers

FGF Series



Item # _____

FGF-24-HC FGF-36-HC FGF-50-HC
 FGF-24S-HC FGF-36S-HC FGF-50S-HC

Standard Features

- Our glass frosters / chillers units are designed with durability and strength along with feature rich standards uncommon in the industry today.
- **Exclusive 4 heavy duty shelving system** with slides in order to take full advantages of your capacity without sacrificing any space.
- With innovative and eco-friendly technology, Fagor utilizes R-290 Hydrocarbon designed to meet DOE's Energy Conservation standards with very low contribution to global warming (ODP-0) (GWP-3).
- Digitally controlled refrigeration cold wall system for a wide range of temperatures throughout the box to ensure a frosted or chilled product at all times.
- Heavy duty 18 gauge stainless steel top with stylish wear resistant black vinyl front, sides and back. (S) Models have a stainless steel front and sides Galvanized back.
- Units come with compressor mounted on the right side with service friendly slide out rail system. Drain is located in the back compressor house.
- Shelving slides from one side to the other on both top and middle shelves for a maximum usage.



FGF-24S-HC



FGF-36-HC



FGF-50-HC



*Conforms to UL & NSF-7 standards

Options & Accessories

- 220 volts / 50 cycles / 1 phase

Glass Frosters / Chillers	Model	Doors	Case Capacity		Amp	HP	Volt	NEMA Plug	Cabinet Dimensions			Shipping	
			8 oz. Mugs	10 oz. Steins					W	D	H	Wt. Cubes	
	FGF-24-HC	1	35	96	1.5	1/3	115	5-15P	24-5/8"	26-7/8"	35-3/4"	176	13.0
	FGF-36-HC	1	60	162	1.5	1/3	115	5-15P	36-5/8"	26-7/8"	35-3/4"	234	19.7
	FGF-50-HC	2	84	234	2.5	1/2	115	5-15P	49-5/8"	26-7/8"	35-3/4"	269	27.5
	FGF-24S-HC	1	35	96	1.5	1/3	115	5-15P	24-5/8"	26-7/8"	35-3/4"	176	13.0
	FGF-36S-HC	1	60	162	1.5	1/3	115	5-15P	36-5/8"	26-7/8"	35-3/4"	234	19.7
	FGF-50S-HC	2	84	234	2.5	1/2	115	5-15P	49-5/8"	26-7/8"	35-3/4"	269	27.5

(S) Stainless steel units / (G) Glass door units.

JULY 2021

13105 NW 47th Ave. Opa-Locka FL 33054
 Tollfree: (866) 463 2467 Ph: (305) 779 0170 Fax: (305) 779 0173
 info@fagorcommercial.com
 www.fagorcommercial.com

TOGETHER WE EVOLVE

Specifications

Construction

Heavy duty stainless steel top, 18 gauge. Black vinyl front, sides and back. (S) Models have stainless steel front, sides and back. Interior constructed of heavy duty galvanized steel walls with covered corner galvanized floor. Lids are heavy duty foamed in place with stainless steel finish. Entire cabinet is insulated with 2" foam-in-place Ecomate insulation. Polyurethane insulation with zero ozone depletion (ODP) and zero global warming (GWP).

Refrigeration System

Self-contained capillary tube system using environmentally friendly (CFC Free) R-290 refrigerant. Front breathing compressor on right side for built-in applications. Evaporator coil is mounted to interior back panel. Large fan motor and fan blades for greater air flow. Automatic condensate evaporator, drain connection required. Evaporator condensate has been plumbed to a condensate pan located in the compressor housing. Access for the condensing unit behind the front grill, slides out for easy cleaning and maintenance. Cabinets are designed to maintain temperatures between 0° F to -7° F in the interior cabinet.

Shelving

Shelving: (2) Sliding shelves with glass guards, (2) sliding shelves without guards, (2) flat floor shelves.

Others

Unit is supplied standard with an 8' cord and plug (Nema 5-15p).

Warranty

3 year parts and labor warranty plus 2 additional year compressor warranty. (Continental U.S.A. & Canada only).

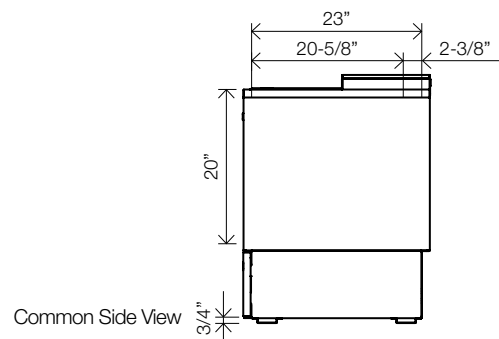
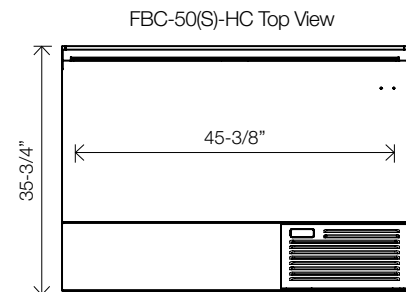
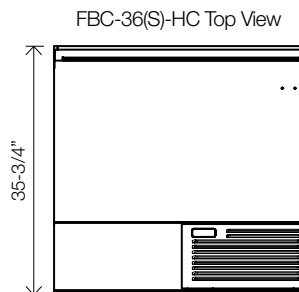
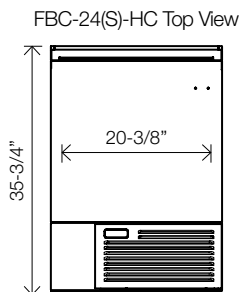
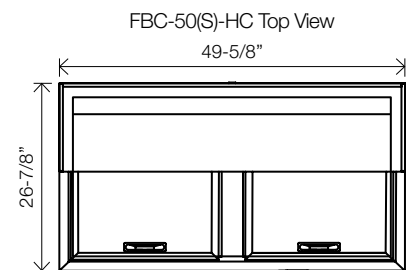
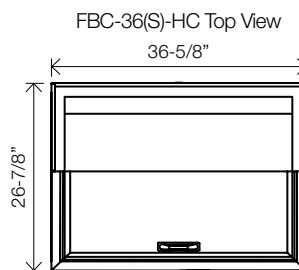
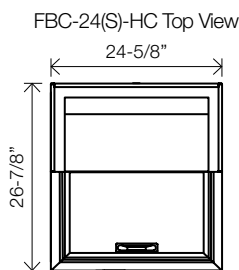

The manufacturer reserves the rights to modify materials and specifications without notice.