



Project _____

Item No. _____

Quantity _____

X5 ALL IN ONE OVEN/PROOFER

5 PAN CAPACITY - TOUCH SCREEN PROGRAMMABLE CONTROL



ELECTRIC

- 1 PH - 208V - 50 A - 10.4 kW - 60 Hz - 2 wires + Ground - NEMA 6-50P
- 1 PH - 240V - 50 A - 10.4 kW - 60 Hz - 2 wires + Ground - NEMA 6-50P
- 3 PH - 208V - 30 A - 10.4 kW - 60 Hz - 3 wires + Ground - NEMA 15-30P
- 3 PH - 240V - 30 A - 10.4 kW - 60 Hz - 3 wires + Ground - NEMA 15-30P

DESCRIPTION

The all new NU-VU X5 has exclusive patented technology that allows you to proof, bake and steam in the same cavity. Save time and labor by not needing to continually return to the unit and move product from the proofer cavity to the oven cavity.

An added steam function allows you to do all types of products including artisan style breads.

The sleek new look and cool-to-the touch door allows you to use the unit in front of the customers to visually upsell your fresh product and increase sales.

FEATURES & BENEFITS

- Elegant and sophisticated
- Cool-to-touch door for added safety
- Easy to use touch screen controls featuring 32 programs with 8 stages
- Wi-Fi capabilities
- Patented technology

OPTIONS

- Stand with doors (113-4040)
- Stand without doors (113-4044)

Sheet Pans	13"x18"	18"x26"	Spacing
Oven	10	5	4 1/2"

X5

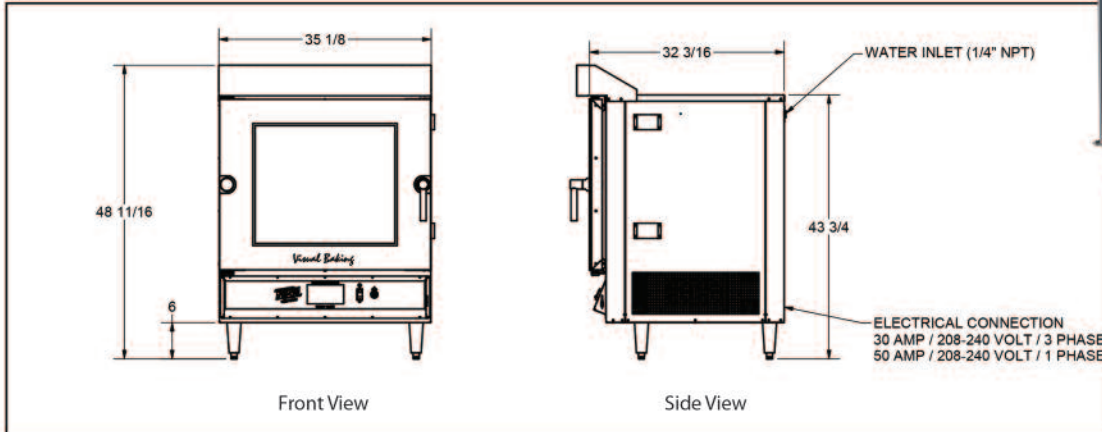

STANDARD PRODUCT WARRANTY

2 year parts, 1 year labor limited warranty

X5 Specs

Model	Overall Dimensions			Interior Dimensions			Shelf spacing	Clearance			Water Inlet	Shipping Weight	Freight Class
	W	D	H	W	D	H		Side	Top	Bottom			
X5	35 1/8" (892)	32 3/16" (818)	48 11/16" (1237)	28" (711)	20" (508)	23 1/4" (591)	4 1/2"	4" (102)	4" (102)	4" (102)	1/4"	485 (220)	85

NU-VU FOODSERVICE SYSTEMS

5600 13th Street, Menominee, MI 49858 USA • Phone: 1-800-338-9886 • Fax: 906-863-5889

www.nu-vu.com

