







Small in footprint, large in performance.

The **CED 400** is the world's narrowest 2-4 valve dispenser in its class. Boasting the latest technology for energy savings and sustainability, and the flexibility to offer carbonated and non-carbonated beverages, the **CED 400** is your solution to delivering what your customer wants.

Features

-  Narrow width - 10.8" (275 mm)
-  R290 Refrigerant
-  Reduced energy consumption
-  Available with 2, 3, & 4 LPV valves
-  Consistent internal cold carbonation
-  Removable refrigeration deck for ease of service
-  Stainless steel construction
-  Lancer Electronic Ice Bank Control
-  1/3 hp compressor

Accessories and Options

- Illuminated LED Merchandiser
- Outlet LED Indicator (CO2, syrup, and water)
- Internal mini syrup pumps
- Key Lock Switch
- Leg Kit

Certified by these agencies:



CUSTOMER SERVICE

Should you require more information about our products, please do not hesitate to contact our customer service team at custserv@lancerworldwide.com.



WARRANTY

For warranty specifics by product, contact your Lancer Sales Representative. Equipment design and/or specifications are subject to change without notice.

For more information visit lancerworldwide.com or call 1-800-729-1500

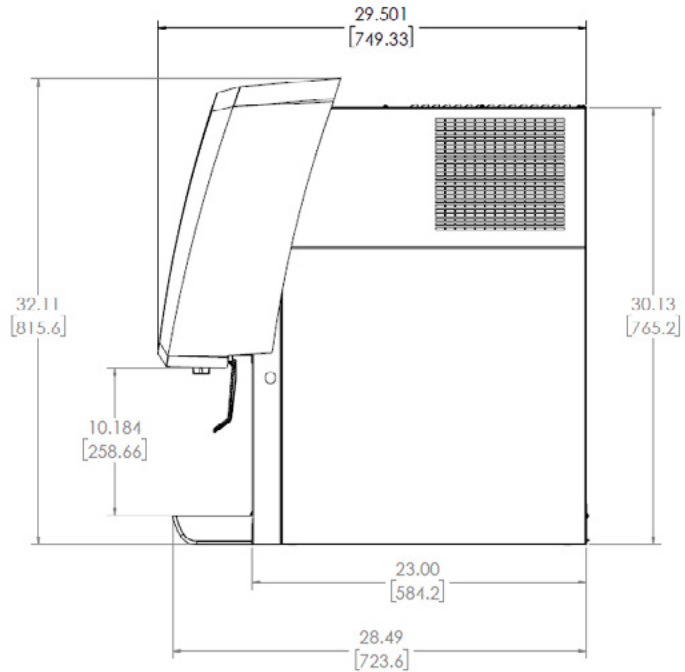
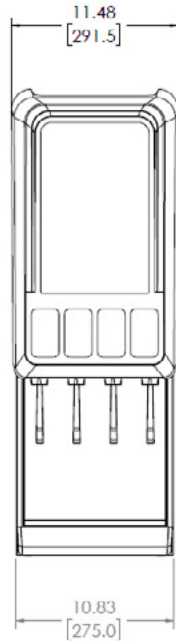

Distinctive Design

Flexible carb to non-carb dispensing

2-valve		C/NC	C/NC	
3-valve		C/NC	C/NC	C
4-valve	C	C/NC	C/NC	C
	Valve 4	Valve 3	Valve 2	Valve 1



Dimensions

30" H x 10.8" W x 28" D
(764 mm H x 275 mm W x 719 mm D)



Weight

Empty: 146 lbs (66.2 kg)
Operating: 193 lbs (87.5kg)
Shipping: 160 lbs (72.5kg)



Ice Bank

Capacity: 14 lbs (6.4 kg)



Electrical

115V/60Hz, 6 Amps
220V/50Hz, 3 Amps
220V/60Hz, 3 Amps



1/3 hp Compressor

285W (115V/60Hz)
450W (220V/50Hz)
400W (220V/60Hz)

For more information visit lancerworldwide.com or call 1-800-729-1500

6655 Lancer Boulevard • San Antonio, TX 78219 • 210-310-7000 • Fax: 210-310-7250 • © 2021 Lancer® Worldwide • CED 400 02/22

"Lancer" and "Lancer Worldwide" are trademarks of Lancer Corp. © 2021 by Lancer®, all rights reserved.