



Project:
Item:
Quantity:

**COMBIVAC BOXER 42XL
CHAMBER VACUUM SEALER**



FEATURES

- Seal bar length: 16.5"
- Seal bar with two wires, for double security
- Seal bar easily removable for cleaning and maintenance purposes
- Pump capacity: 889 cf/h (25 m³/h) Busch vacuum pump
- Pump maintenance and cleaning program
- Machine cycle: 20-40 sec
- **Standard CombiVac control system** with 20 program memory and Sensor control: max. 99.8%, for an optimum and consistent vacuum and cycle time
- Soft Air to protect the product and vacuum pouch
- Transparent lid, opens automatically after every cycle
- Deep drawn vacuum chamber
- Comes with insert plates for a faster cycle and product adjustment
- Stainless steel exterior
- 6ft cord with Nema 5-15P plug
- Standard with service kit

DESCRIPTION

The robust, stainless steel Boxer 42XL vacuum sealer is standard equipped with a Busch vacuum pump. This CombiVac table-top model is ETL listed and complies with UL, CSA and CE standards.

OPTIONS AND ACCESSORIES

- Liquid control
- Inclined insert plate
- Cut-off seal (\$0)
- Wide seal (\$0)
- Label printer
- Food container adaptor
- Cart with castors and shelf



WARRANTY

Henkelman Inc offers a warranty of 1 year on labor and 3 years on parts. For full warranty details, please refer to www.henkelman.com.

DATE

APPROVAL



FIT FOR FOOD SERVICE

<https://www.henkelman.com/us>

HENKELMAN INC.
493 W Fullerton Ave
Elmhurst IL, 60126

Sales and technical support
P +1 331 979 2013
F +1 630 359 3875
E info@henkelmanusa.com
Service and warranty
P +1 844 208 5685

COMBIVAC VACUUM SEALER BOXER 42 XL - SPEC SHEET

COMBIVAC VACUUM SEALER BOXER 42XL – SPECS

COMBIVAC VACUUM SEALER BOXER 42XL – SPEC SHEET

DIMENSIONS

In inches

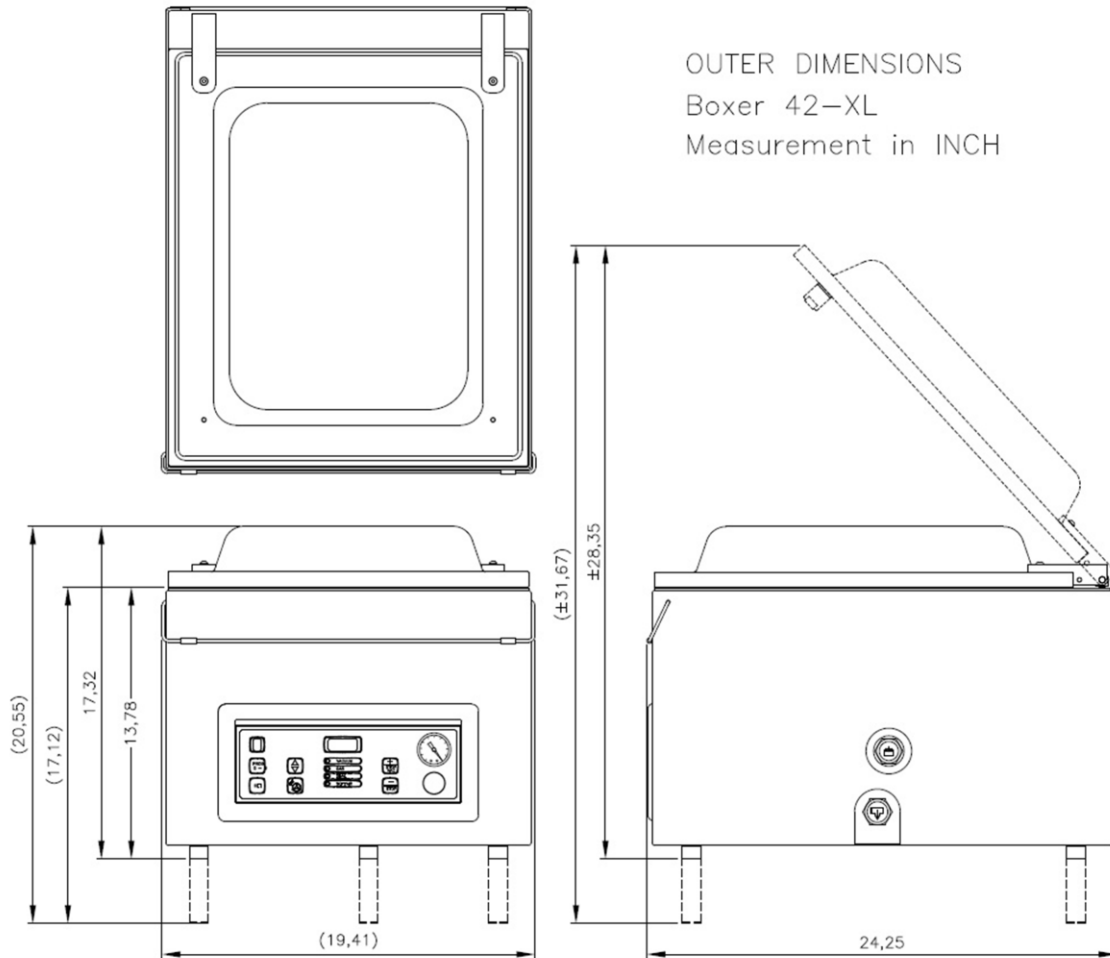

Model	Dimensions (inches)		Volts	Amps	Hz	Pump capacity	HP	Plug	Weight (lbs)
	Chamber (usable space) LxWxH	Machine LxWxH							
Boxer 42XL CombiVac	18"x16.5"x7"	24.2"x19.4"x17.3"	110-120V	13	60Hz	889 cf/h (25 m ³ /h)	1.34	NEMA 5-15P	159



ORIGINAL HENKELMAN
VACUUM SYSTEMS

FIT FOR FOOD SERVICE
<https://www.henkelman.com/us>

HENKELMAN INC.
493 W Fullerton Ave
Elmhurst IL, 60126

Sales and technical support
P +1 331 979 2013
F +1 630 359 3875
E info@henkelmanusa.com
Service and warranty
P +1 844 208 5685