



# SR60B-24MD2

## Mega Top 60" Prep Refrigerator with One Door and Two Drawers

### STEELHEART



SR60B-24MD2  
11/08/21  
Item # 13647

#### W x D x H

60" x 34" x 44.25"\*  
\*with 6" casters



Item #: \_\_\_\_\_

Project: \_\_\_\_\_

Qty: \_\_\_\_\_

AIA#: \_\_\_\_\_

## Features

► Engineered to maintain NSF-7 temperatures in 100°F ambient. (Certified to NSF-7 temperatures in 86°F ambient.)

► Stainless steel exterior front, sides and top with stainless steel interior sides, back, and floor

► Front breathing air flow design

• Environmentally friendly R290 hydrocarbon refrigerant

• Cabinet and doors are insulated with 2" CFC free, foamed in place polyurethane

• Innovative air distribution system distributes air evenly to maintain product temperature

• Provided with a full complement of polycarbonate plastic 1/6th size pans, 4" deep and adapter bars

• Rails will also accept 6" deep pans for 50% more pan volume

• 60" x 10" x 1/2" thick white polyethylene cutting board is standard

• Drawer module frames, acetal rollers, and drawer stops are formed of heavy duty stainless steel all welded construction and securely fastened in the cabinet

• Top drawers will accommodate (1) 12 x 20 full size pan and (2) 1/4 size pans. Bottom drawer will accommodate (1) full size pan

• Top and bottom drawers allow for 6" deep pans

• Extruded aluminum flush mount drawer handle

• Magnetic door gasket is easily removable for cleaning

• Removable stainless steel prep guard simplifies cleanup from accidental rail pan drips and spills

• Hot gas condensate removal

• E-coated evaporator coil

• Standard with 6" stem casters (two with brakes)

• 10 ft. cord and plug

Note: Made to order. Allow 4-6 weeks.

Door or drawer can be located in any section of the cabinet. Location must be indicated at time of ordering.

Hoshizaki reserves the right to change specifications without notice.



### Dimensions / Capacity

Interior Storage Capacity (CF) (AHAM)	14.8 ft <sup>3</sup>
Overall Width x Depth (including 1" bumper)	60" x 35"
Height (including 6" casters)	44.25"
Depth with Cutting Board Installed (including 1" bumper)	37.5"
Door Opening Width x Height	25.5" x 23"
Depth with Drawer Fully Open (including 1" bumper)	52"
Depth with Door Open at 90° (including 1" bumper)	58.5"
Pan Capacity (# of 1/6 size x 4" deep)	24
Adjustable Shelves / Shelf Dimensions (W x D)	1 / 27.25" x 16"
Crated Shipping Weight	420 lbs.
Crated Length x Width x Height	62.5" x 36" x 46.5"

### Two-Section SR60B-24MD2

### Electrical / Refrigeration

Two-Section SR60B-24MD2	
Voltage	115/60/1
HACR Breaker	15.0 Amps
Electrical Connection (NEMA)	5-15P ⚡
Voltage Range	104-126
Ambient Temp. Range	45° to 100°F
Control Setpoint Range	32° to 52°F
Amperage	4
Energy Consumption (kWh/day) @NSF	4.05
Heat Rejection (BTU/Hr.) @NSF	575
Approx. Nominal Compress. BTU/HR (HP)	2431 (1/3HP)
Refrigerant / Charge Amount (oz)	R290 (2.5 oz)

### Two-Section SR60B-24MD2

### Options

- 2.25" Casters
- 4" Casters
- Stainless steel lift off covers
- Additional Epoxy Shelves
- Stainless steel shelves
- Overshelves
- Stainless steel back
- Drawer divider bars
- Rail adapter bars
- Composite cut. board (HS-5268)
- Foot pedals- Left hinge (HS-5555)
- Foot pedals- Right hinge (HS-5556)

### Warranty

3 Year - parts and Labor on entire machine.  
5 Year - Parts on Compressor  
Valid in United States, Canada, Puerto Rico and U.S. Territories. Contact factory for warranty in other countries.



# SR60B-24MD2

## Mega Top 60" Prep Refrigerator with One Door and Two Drawers

STEELHEART

SR60B-24MD2  
11/08/21  
Item # 13647

FRONT VIEW

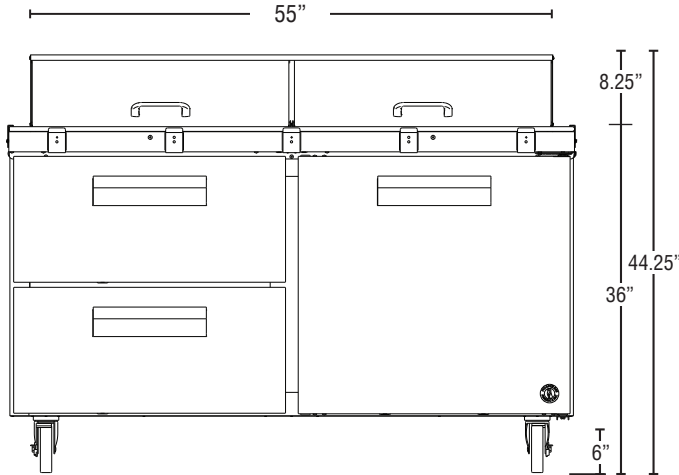

SIDE VIEW

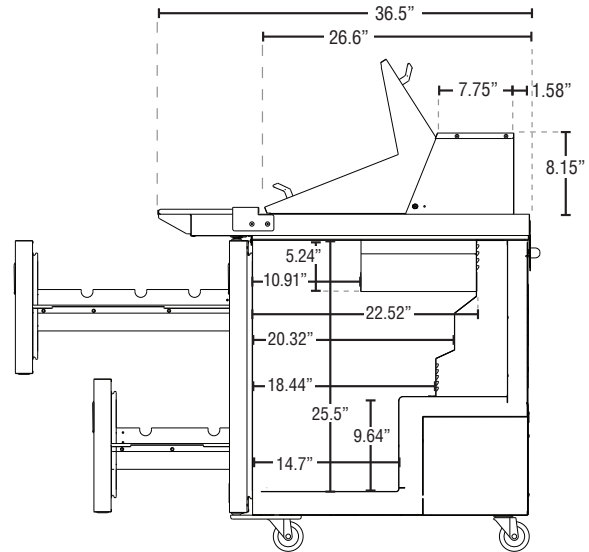

PLAN VIEW

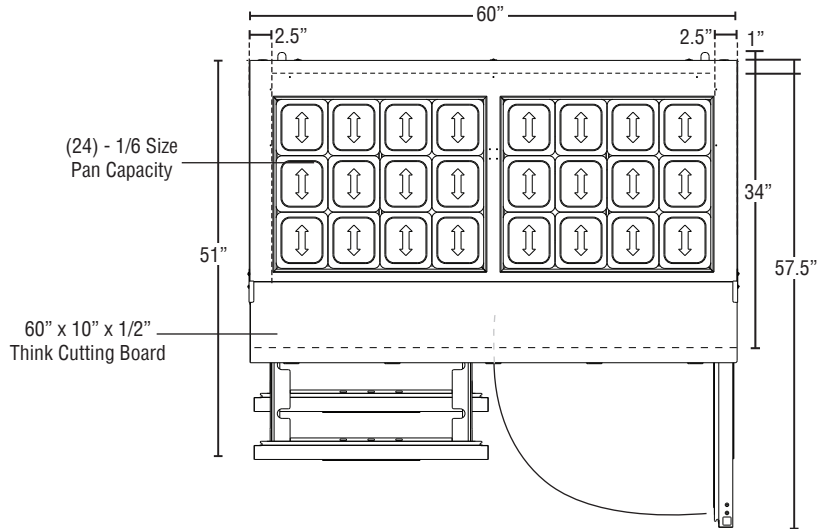

### Cabinet Construction

The exterior cabinet top, front, and sides, are constructed of high quality stainless steel. Cabinet is provided with a stainless steel top enclosure and an easily removable stainless steel insulated lift-up cover. The exterior back and bottom are constructed of coated steel. The cabinet interior back and sides are stainless steel with an ABS ceiling and stainless steel floor. Cabinet walls and drawers are insulated with 2" CFC free, foamed in place polyurethane. 6" polyolefin, stem casters (two with brakes) are standard. Preparation tables are supplied with a full length, 10" deep x 1/2" thick N.S.F. approved white polyethylene cutting board.

### Drawer Construction

Drawer fronts are constructed of high grade stainless steel inside with stainless steel interior liners and are insulated with 2" CFC, foamed in place polyurethane. The bottom drawers will accommodate 6" deep pans. Full size pans in the top drawer can be oriented longways from front to back or left to right. The top drawer will accommodate 4" deep pans with either orientation. The top drawer will also accommodate 6" deep full-size pans when oriented longways from left to right and provide capacity for (2) 1/4 size pans 4" deep in the rear of the drawer. HS-5433 divider bar is recommended for this configuration. The drawer slides are constructed of heavy duty 16-gauge stainless steel and durable acetal rollers with stainless steel ball bearings to prevent metal to metal contact. The drawer slides have a dynamic load capacity of 175 lbs. and have been life tested (fully loaded) three hundred thousand openings and closings without showing significant wear.

### Door Construction

Doors are constructed of high grade stainless steel exterior with an ABS interior liner and are insulated with 2" CFC free, foamed in place polyurethane. Hoshizaki's exclusive "stepped" design protects the gasket while product is removed from the cabinet. Spring assisted self-closing doors are equipped with a stay open feature past 90 degrees. Field reversible door hinging is standard. Doors & drawers are provided with a one piece, extruded aluminum, flush mount handle. Snap-in magnetic door gaskets are durable and easily removed for cleaning.

### Refrigeration System

Front breathing refrigeration system allows unit to be built into any enclosure with zero side or rear clearance. The high efficiency refrigeration system is self-contained with an E-coated evaporator for extended life. Condensate removal is accomplished with an energy efficient non-electric evaporation system. A capillary tube controls the flow of environmentally friendly R290 refrigerant through the evaporator. Unit uses a heated, time initiated defrost to eliminate any ice on the evaporator coil. An innovative air distribution system distributes air evenly around the pans. Engineered to maintain NSF-7 temperatures in 100°F ambient. (Certified to NSF-7 temperatures in 86°F ambient.) Preparation tables are supplied with a full complement of N.S.F. approved plastic 1/6 size pans, 4" deep and stainless steel adapter bars. Units will also accommodate 6" deep pans. Pans are located 1.5" below the top to keep food product within easy reach. 115 volt units are equipped with a ten foot cord and NEMA rated plug (20.0 amps or less).