

Job: _____

Item: _____

Quantity: _____

Queen Mary - Aluminum

These units are built for transporting big loads for banquets, catering, and bussing. The solid shelves have marine edges that add strength and contain spills.

- Framework is constructed of 1 3/4" x 1 3/4" x .100" wall Queen Mary Tube (tube with 3/4" radius to the outside of unit).
- Shelves are constructed of .080" sheet aluminum reinforced with 1 1/4" x 1 1/4" x .070" wall tubing.
- Base is constructed of 1 3/4" x 1 3/4" x .070" wall tubing.
- Equipped with four 8" platform type casters, two swivel and two rigid.
- Five-Year Guarantee against material defects and workmanship.
- Lifetime Guarantee against rust and corrosion.
- NSF Certified.



1455

Model No.	Size D-H-L	Weight Capacity	No. Shelves	Shelf Spacing	Ship Lbs.
1450	29" x 66 3/4" x 62"	3000 lbs.	5	12"	186
1451	29" x 66 3/4" x 75"	2500 lbs.	5	12"	210
1452	29" x 66 3/4" x 62"	2500 lbs.	4	16 1/2"	174
1455	29" x 66 3/4" x 62"	3000 lbs.	6	9 1/4"	205

Four 8" platform type casters—two swivel (#C526) two rigid (#C527).

Each Unit Is Equipped With A Full Perimeter Bumper.

Options:

"CL(E)"— see catalog for details.

Towing Options Available — Call For Pricing

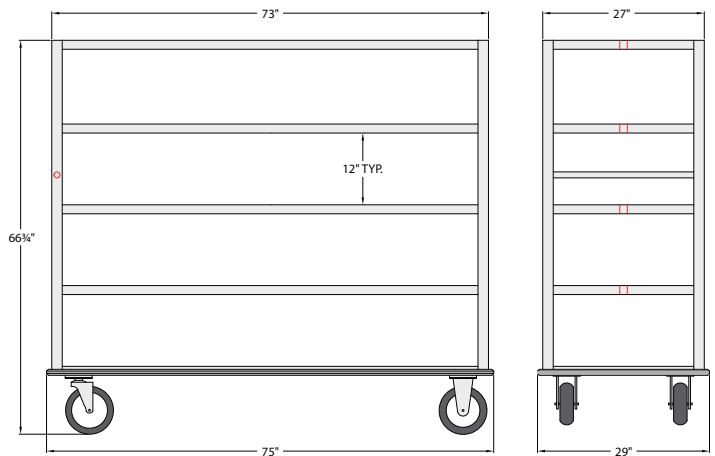

1451

This information is for general sales and engineering use only. New Age Industrial reserves the right to modify or make changes at any time without notice to materials and specifications.

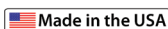

Distributed by: