



SPECIFICATION SHEET

Model #:	Qty:
Project #:	
Consultant:	

QUALITY FOOD SERVICE EQUIPMENT

OVER SHELF



DIMENSIONS

double rack - table mounted

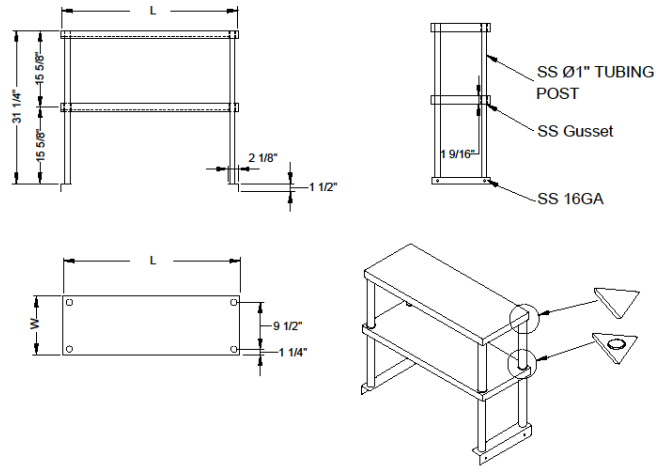

MATERIAL

- ◆ 18GA 300 stainless steel

FEATURES

- ◆ Includes 2 racks (1 fixed & 1 adjustable)
- ◆ Safety square turn down edge

Model#	Length	Width
TMS-1236D	36"	12"
TMS-1248D	48"	12"
TMS-1260D	60"	12"
TMS-1272D	72"	12"
TMS-1296D	96"	12"

Model#	Length	Width
TMS-1836D	36"	18"
TMS-1848D	48"	18"
TMS-1860D	60"	18"
TMS-1872D	72"	18"
TMS-1896D	96"	18"