



PROJECT

ITEM NO: \_\_\_\_\_

QUANTITY: \_\_\_\_\_

# Stainless Steel Work Tables

## Galvanized Leg & Undershef Series



NSF STD.2  
Certified

### FEATURES & CONSTRUCTION:

- Top is fabricated with 1-1/2" rounded edges on both working sides and flat edge on both ends.
- Table top edges formed with hemmed edges to provide extra rigidity and safe to touch finish.
- Reinforced table top with two sound deadening galvanized steel hat channels. Note: Three sound deadening hat channels on 30" & 36" deep tables.
- Adjustable undershef secured to legs with aluminum die cast clamps allowing undershef to be approximately 2" wider and 2" deeper than leg tube welded to undershef style.
- All exposed welded areas smooth polished to brush finish sanitary #4.
- Welded galvanized steel leg sockets with two point leg fastening.
- All tables shipped K.D., but easily assembled.



\* 84" tables and longer come with 6 legs

### MATERIAL:

Top: 18 Gauge Stainless Steel - 400 series  
 Shelf: 18 Gauge Galvanized Steel  
 Leg: 1-5/8" Galvanized Steel Tubing with 1" Adjustable Plastic Bullet Feet

### Galvanized Undershef Series

W	14"	18"	24"	30"	36"
L	MODEL NO.				
24"	SMT-1424G	SMT-1824G	SMT-2424G	SMT-3024G	
30"	SMT-1430G	SMT-1830G	SMT-2430G	SMT-3030G	
36"	SMT-1436G	SMT-1836G	SMT-2436G	SMT-3036G	SMT-3636G
48"	SMT-1448G	SMT-1848G	SMT-2448G	SMT-3048G	SMT-3648G
60"	SMT-1460G	SMT-1860G	SMT-2460G	SMT-3060G	SMT-3660G
72"	SMT-1472G	SMT-1872G	SMT-2472G	SMT-3072G	SMT-3672G
84"	SMT-1484G	SMT-1884G	SMT-2484G	SMT-3084G	SMT-3684G
96"	SMT-1496G	SMT-1896G	SMT-2496G	SMT-3096G	SMT-3696G
108"	SMT-14108G	SMT-18108G	SMT-24108G	SMT-30108G	SMT-36108G
120"	SMT-14120G	SMT-18120G	SMT-24120G	SMT-30120G	SMT-36120G

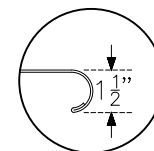

Rolled Rim Edge  
Front And Rear  
Reinforced with  
Hemmed Edge

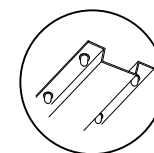

Two (three on 30" & 36" deep) Hat Channel Reinforced Top. Attached to Underside of Top via Studs Welded to Underside of Top, Adhesive and Stainless Steel Acorn Nuts.

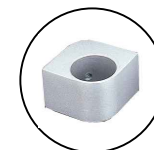

Aluminum Die Cast Clamp For Adjustable Undershef



Plastic Bullet Feet  
1" Adjustable



Rev. 01/21

SAPPHIRE MANUFACTURING  
 Tel: 718-543-2111  
 Fax: 718-543-2121

info@sapphiremanufacturing.com  
 WWW.SAPPHIREMANUFACTURING.COM



PROJECT

ITEM NO:

QUANTITY:

# Stainless Steel Work Tables

## Galvanized Leg & Undershef Series



NSF STD.2  
Certified

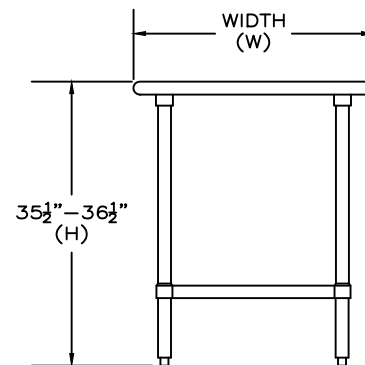
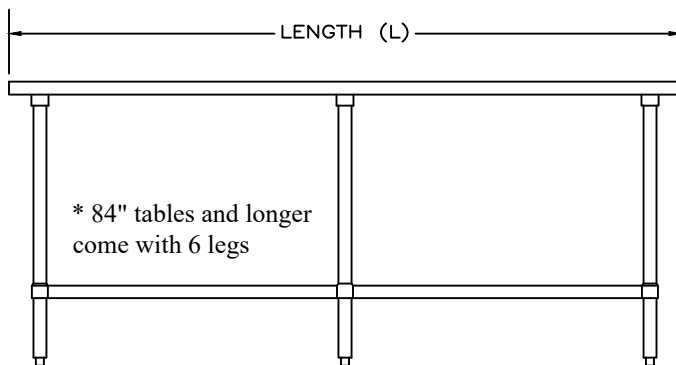
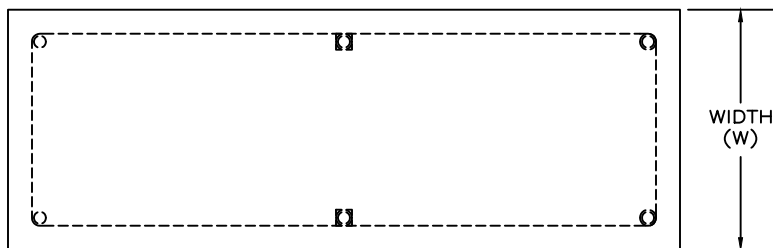
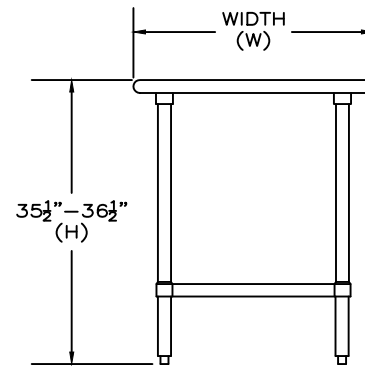
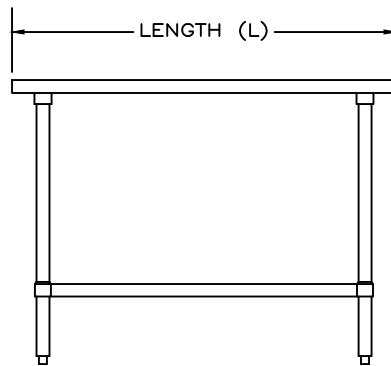
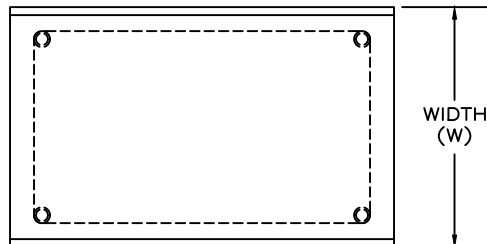

Specifications subject to change without notice.

All dimensions are typical (Tolerance 1/2").



Rev. 01/21

SAPPHIRE MANUFACTURING  
Tel: 718-543-2111  
Fax: 718-543-2121

info@sapphiremanufacturing.com  
WWW.SAPPHIREMANUFACTURING.COM